

Falsifying Feminine Pneuma: A Study of 'Draupadi' in M.T.'s *Second Turn*

Abstract

M.T Vasudevan Nair's widely credited novel *Second Turn*, is set as a retelling of the Indian epic *The Mahabharata*, from the perspective of Bhima, the second Pandava. The novel deviates from the traditional story of The Mahabharata when Bhima stops to take care of Draupadi during his journey. The author avoids divine elements of the epic in an attempt to portray the story as a real incident that happened in prehistoric India. In the *Second Turn*, Draupadi is not depicted as the protagonist of his classic work but as a co-wife of the protagonist Bhima. What M. T has done through his work is the usual practice of patriarchy, where women are always blamed for everything and are fitted in to the framework of the norms and conventions of the male dominated society. The focus of my study is to analyse how the picture of Draupadi is painted by a male author. The novel delineate the picture of patriarchal society in which the role of woman was to serve only her husband and elders. While standing in a neutral, unbiased, unprejudiced position, I am trying to examine the female character, Draupadi, in a variety of roles : as an individual, daughter, wife, lover, mother; and considering how the aspects like race, class, gender and other cultural factors mould the female psyche and how the humanly emotions like joy, pain, anger, jealousy, surprise etc. affects Draupadi as a human being.

From the very first breaths, humans are taught to follow a strict code of behavior that differs depending on their gender. The notion of female subjugation and male domination begins at the very moment of child's birth. In the words of Michele Barrett, the meaning of gender in patriarchal ideology is, "not simply 'difference,' but...division, oppression, inequality, interiorized inferiority for women" (154). Forcing men and women to fit into gender roles is damaging as it leads to the belief that these roles represent truth, causing gender stereotypes to endure. It also forces men and women to experience life only from their point of view as men and women, not as human beings.

"The behavior considered appropriate to each gender becomes severely restricted and polarized. In a male dominated society, being a man means not being like a woman" (Gardiner 189).

Meera Prasannan

Assistant Professor on contract
Dept. of English
Assumption College, Changanacherry
Kottayam Dist.
E-mail id:
meerakailas915@gmail.com
Mob: 9526961478

These differences and distinctions get reflected in literature which is truly a mirror held up to the society. Certain emotions, certain basic human motives are arbitrarily categorized by the rule makers as 'feminine.' One surely gets a whiff of pre-emotions rather than legitimate empathy, while going through the male writers' authorial attempts to represent a female point of view.

For many centuries, history and religion have been striving to reinforce the Divine Right theory of male supremacy. As the handmaid of religion, literature too has a vital role to play in strengthening the disparity between male and female. Women have always been given a secondary status in the sphere of family and society. They are prescribed a certain dress-code and speech-code along with numerous other restrictions. The patriarchal system has been imposed upon women from time immemorial and, naturally, they did not realize the ulterior motives of the gendered enemy and took this system for granted. Injustice in the form of subjection of women has been levied upon in the name of tradition and convention. In such a society, they are not encouraged to be part of the mainstream and are chucked to the periphery. Male writers have been perpetuating this discrimination through their fictional gender stereotypes.

The novel *Second Turn* displays M.T Vasudevan Nair's phenomenal adroitness in weaving the manifestations of his own genius into the magnificent fabric of Hindu mythology and the great epic *Mahabharatha*. In the novel Bhima is not shackled by the high sounding philosophy or the rigid and stringent Aryan code; on several occasions, particularly in his relationship with Draupadi. M.T, himself being an emissary of the dominant patriarchy, it is pertinent to note the manner in which he portrays womanhood. This aspect invites popular attention to yet another thought provoking question, how far is it possible for a writer who has transcended gendered bias to give life to the characters that represent the hitherto unequal gender.

However, M.T makes it plain that he has not changed the frame work of the story put together by the first Vyasa, Krishnadwaipayana. Adhering to the traditional framework, M.T draws the portrait of Draupadi, a woman, through the consummately masculine perspective of Bhima. Exactly at this point lays the universal appeal of the work that is the portrayal of a woman, in her glorified incarnations viz. mother and wife, through the perspective of a man. But the very climax of this endeavour reveals Draupadi's deplorable status as a mere tool to catalyse the writer's ultimate effort to bestow Bhima with heroic grandeur. The reader is provoked to demand an answer for the haunting query that whether M. T too had borrowed from the overused tactic of the clever and manipulative patriarchy, that is, deny women their very voice.

From the very first chapter titled 'The Journey' onwards the author manipulates events and circumstances for the character of Draupadi to radiate intensely feminine qualities so that the process of stereotyping may progress with great facility. In the case of Bhima, the very scene in which he is introduced itself is eloquent about those peerless virtues and rare gifts with which he is ordained. Yet another factor that underscores Bhima's indubitable worth is his intense love and concern for his wife Draupadi when juxtaposed with the other four that complement the formidable wedlock of six.

Bhima stood listening to a sigh and a suppressed dirge. He could recognize that sound in the midst of any uproar. Draupadi has fallen down. He stood beside the thorny shrubs on the dry, cracked earth (5).

On the surface the authorial attempt is to throw light on the unbreakable and sacred bonding that the husband feels for the wife but, before the eyes of the meticulous reader, he betrays his ulterior motive to reaffirm and highlight Bhima's position as the noble hero, the epitome of the whole array of covetable virtues. While progressing with this vested interest, the writer takes maximum care to avoid such instances which may fade the supreme glow of his hero. For instance, when it is time for him to burst out with an open criticism on Draupadi who is an utter fiasco as an ideal wife, he

thrusts this overtly patriarchal verdict into the revered and righteous Yudhishtir. This serves dual purpose 1) Bhima is freed of from seen as being that rude, 2) Draupadi, the representative of the weaker sex, is 'duly' abused. "I am not surprised," says Yudhishtir, "Long ago she lost the spirit to reach the feet of God. She loved only Arjun, as she sat in the durbar with me, her eyes were fixed on Arjun" (6).

Bhima's reluctance to defend Draupadi and hesitance to abandon her is a clever paradoxical instance contrived by the author. The result is plain, the readers' admiration for Bhima conquers new peaks and so too is their contempt for the capricious and feminine (which is usually equated with evil in the patriarchal set up) Draupadi. Draupadi's culpable inability to gauge the depth of Bhima's love is vaguely yet triumphantly insinuated through many similar instances. Finally it is for the sake of the forsaken and impoverished Draupadi that Bhima renounces even the very 'summum boum' of life on earth, 'Moksha.' "Bhima forgot the cardinal law of the last march. He turned round.... At a moment when he had forgotten all rules and strictures, he turned his back on the beckoning mountains" (6).

Once more the told and retold story of the temptress leading Man away from the Father and His heavenly abode is repeated, but under a new guise. Here, on the face of a crestfallen Draupadi, Bhima sees the ebb and flow of a powerful current of mixed emotions. Draupadi appears to Bhima as a mysterious being, and the author with great cunning, distorts her mental state as springing from a plea to be forgiven, or a warm expression of gratitude, or a husband curse against the cruel fate. Draupadi's silence, which is too stubborn to be broken, is misrepresented by the male genius as the vaulting guilt that preys on her mind and the guilt is the natural product of grievous sins committed by the whimsical feminine entity. "She looked up at Bhima's face as he sat embarrassed not knowing how to help her. Bhima noticed silent questions crowding her face" (7). Once again, Draupadi's silent apologizing contrived by the author with great cunning highlights Bhima's glory at the expense of the other.

The novel, from the very start to the catastrophic finale, is replete with instances in which man, the mighty sex; assert his superior dominance on various planes. Woman's inferiority and need to be submissive are reiterated so that she finds herself eclipsed by the male sovereignty physically, mentally and intellectually. M.T makes his pro-patriarchal stand quite pronounced. Half the bulk of the novel is dedicated to the praise of martial prowess and intellectual accomplishments of Bhima and his illustrious brothers. The very same author, when it comes to the shrewdness of the female protagonist, takes of an alleging tone rather than that of admiration. Also, as against the privileged male sex, women are diagnosed with culpable deviousness when they display interest in statecraft and diplomacy. Kunti, who considers the savage woman and her five children as expendable ransom and Draupadi herself, who hatches evil tactics to tighten her hold over the queenly crown are depicted as root of all evils. The critical reader is struck by the author's zealotry to lay stress on these aspects that inevitably end up in tarnishing the honour of these women.

Draupadi is not M.T's heroine and he makes it a convenient pretext to eclipse her personality and perspective with those of the Man Bhima. The stress, justifiably lies on the hero's thought mechanism and behavioural domains and reactions; the phenomenal expertise that M.T reveals in this process is conspicuously absent in the portrait of Draupadi. Consequently, unlike Bhima, Draupadi has no past, and her acts have no reasonable justifications. She is but a doll that dances to the played tone of patriarchy and finds her lacking in a voice to make her known. She becomes yet another feminine stereotype that personifies suffering and silent submission, the two great female virtues praised by the other sex.

The negligence suffered by man is worthy of M.T's consideration but the same mishap that haunts Draupadi both as an individual and more importantly as a woman who is discarded by the

androtext. Draupadi's hardships are the natural outcome of her own actions and the writer makes his stand clear that none except her can be responsible for that hence the trivialization of the woman's sacrifice- truly an age old hobby of the manly eyes that sees woman as all flesh and womb. Draupadi is ruthlessly charged as being born with the mission of sowing seeds for absolute and ultimate destruction. M.T's Draupadi too is a mute, inglorious and inanimate object.

In Draupadi's unfortunate woman life, one sees the father who gifts his daughter to the illustrious Pandavas, knowing full well that she is to be duly shared by them. This object- status predominates as the story develops: when the husbands with all their might and authority, drew definite boundaries for her love and loyalty on the turn-basis, and when trying desperately to cover her disrobed honour before the vulture gathering (that included her husbands too for whom she was a mere 'play-thing'), when silently acquiescing in to the husbands' desire for other women, and ultimately, when she discovers herself as being no better than a pawn- thing. These circumstances are enough and more to crumble and shatter the life of an ordinary woman and in bearing these tribulations Draupadi presents herself to be an entity beyond the ordinary. However, the writer, instead of exploring this enormous whirlpool of sorrow, disgrace, resentment and mental strain, undermines it out rightly in the most undesirable way. M.T's thrust point is the way Bhima looks at Draupadi, a woman viewed through the eyes of a man. Her heart-breaking lamentations, fierce swearing and labyrinthine thoughts are never the author's cup of tea. He utilizes the hardships of Draupadi to create favourable atmosphere for Bhima to emerge with the noble quality of compassion.

Draupadi's marriage was a typical one of convenience. The entire 'Swayamvara' drama was pre-ordained and Draupadi is given away in marriage with five men- a clear case of polyandry. Here the word 'swayamvara' is stripped of its meanings and throbs with bitter irony. The bride is given no other choice and is denied the right to protest. Karna who proved himself to be an equal rival to Arjun for Draupadi's hand, at least for a moment wins the love and admiration of the princess and could it be true that during one of those moments she whispered the name of Karna to her heart as its conqueror? Nowhere does M. T state that it was Draupadi who rejected Karna, the charioteer's son, on grounds of societal status and other necessary accomplishments. Then on what grounds does the author state that Draupadi was eagerly waiting for Arjun it is to be rightly suspected as yet another patriarchal technique of tyrannically attributing meanings to the feminine silence. What the Pandavas saw in Draupadi was an easy route to embrace their kingdom through the shortcut of the newly established kinship with king Drupada. The chaste and humble fancy of the blushing bride is absolutely lost sight of. "Yudhishtir announced that if Drupada could become our relation, that very moment we could announce that the Pandavas were alive" (80).

Singing dirge to her maidenhood, Draupadi enters her new home where she is welcomed by an array of setbacks. Whatever it may be, M.T reveals his loyalty to patriarchy by refusing to lay bare the cryptic interest that drags Draupadi on to the common plate to be shared by the brothers. Instead he covers it with a protective shield made out by combining the tool in disguise, the mother-in-laws's chastisements especially those done in the name of ethical necessity. The animal passion for Draupadi's feminine flesh is cleverly given the pretext of the promise given to the mother. And the blame is again on another woman whose is sinful enough to weave power tactics which usually is part of statesmanship.

M.T takes care to bestow an initial tone of disapproval on Bhima's mouth when it comes to the issue of practicing polyandry. But without much delay the reader finds another Bhima who betrays silent complaints against Draupadi who had made him wait for long. This impatient eagerness speaks volumes about the masked carnivore within Bhima, within every man. It is equally possible that there might have been frequent quarrels among the five as the sex ratio in the wedlock is highly imbalanced.

In all probability, Kunti must have suggested polyandry as she might have thought it to be the only way out. But the story came out through Vyasa and his successors, it was manipulated as the outcome of Kunti's adamancy and the menfolk were freed of disgrace.

All these incidents underscore Draupadi's status as a tool by which her masters fulfill their desires and achieve whatever they are fascinated by. She is never endowed with human faculties like free thoughts and welling up of emotions. She is even denied the feminine bliss of submitting her unravished virginity to the man whom she has chosen to be her husband. Instead the revolting decision is imposed on her in which she must give herself to her brother-in-laws before to her husband. The shock and deadly grief wrought by such a cruelty is much more than enough to crush the so-called fragile mental make-up of a woman. How can Draupadi help lamenting at least within the private room of her own? Even her devotion and prime concern for her rightful husband is declared by Bhima to be a grievous flaw. Also, her preferring Bhima to Arjuna in fighting Jarasandha during the 'Rajasuya' ceremony, is given meanings about which she was truly innocent. Bhima's masculine prowess in reading between the lines testifies a man's inability to consider the virtuous side of the feminine heart, the purity of her intentions.

M.T's version of Bhima's love is an idealized one as being immaculate and perfect and he repeats this in a parrot fashion via the stories of the golden lotus and the legendary oaths. But it is plain indeed that Bhima's much eulogized 'love' never finds its way to the woman's heart instead it stops where the carnal bliss ends. Why on earth should one call this phenomenon as 'love,' especially when the lexicon provides a more apt word 'lust'?

Woman's chastity is always fathomed according to the scales invented by the masculine shrewdness. In such an attempt he considers moral and ethical codes as flexible and even expendable. Examples are numerous within the novel, such as the practice of polyandry and the public dishonouring of Draupadi. The temporal setting was one in which polygamy was quite common but polyandry was rare. However, the five-fold defilement of Draupadi's body is given the safe cover in the form of yet another tactic, the devising of the concept of 'eternal virginity.' Yet another excuse lies in the previous birth in which Draupadi prayed five times in the whole, for a virtuous husband. However, either because of the lack of authenticity of such a story or because of its professed meaninglessness, M.T abstains from giving such a dimension to his version. It proves to be favourable but fails miserably to ventilate the grievances of Draupadi no matter how very heart-rending they are.

Draupadi is portrayed as rash and capricious as she madly demands the killing of Keechaka, the one who had tried to molest her, again while sending Bhima to procure the golden lotus and even while she ridicules the arch enemy, Duryadhana. Her despised status as the seed of ultimate destruction is repeatedly confirmed. To the themes culled out from the sacred puranas, M.T bequeaths a new vigour and novelty. Even then, Draupadi's picturization as the successor of those enchanting female beauties that intoxicated and seduced the austere sage Viswamitra and the naïve celibate Rishyashringa is carried out quite unhampered. Draupadi wields her alluring sway over the 'upright' male hearts with her dark complexion that resembles the divine grace of Lord Krishna. For the Pandavas, she is more of a show-case thing than a wife, or at the least, an individual. Draupadi apparently seems to be the Indian version of Keats "Ia belle dame sans merci" and Bhima who is persuaded into the quest for the golden lotus appears to be the innocent victim whose heart is throbbing with love in its purest form.

Draupadi is guided by whims and fancies, and this is a much despised quality within the feminine entity which was discovered and branded feminine by the masculine might, hence unquestionable. Draupadi who had expressed her desire to accompany Bhima to get a full view of the magnificent 'Shilanjalam,' later changes her decision for reasons unknown. It remains a mystery for

Vyasa, but the shrewd patriarch in M.T adds it to the numerous indiscretions of Draupadi. Consequently, Bhima loses those beautiful moments with Draupadi as the latter is lost in telling the legends of the heroic Arjun and so shameless of her, she, dreams of her beloved Arjun while on Bhima's bed. Draupadi's fallen state needs no further clarifications but Bhima wins all sympathy by proving himself to be the most unfortunate husband ever lived.

Beauty, the word has as its meaning a beautiful woman also. Beauty is an ornament and weapon for the womenfolk. But many times it proves to be a curse in disguise. At the swayamvara juncture, the humiliation suffered by Karna finds its payment-back through the disrobing of Draupadi at the royal hall. The Bharata tradition glorifies woman's honour, but, at this particular instance, Draupadi's honour is being questioned on grounds of polyandry and the precepts of chastity. These piercing questions that challenged and haunted Draupadi are neglected in *Second Turn* and thus the pangs of womanhood in its entirety, are veiled so that the sole attention of the readers may be fixed on Bhima. The insulting howls at Draupadi are not that much voiced in M.T as he feared that may tarnish the honour of the heroes, who are to be his beneficiaries. Draupadi's suffering is wrought by the insult unleashed on Duryodhana at the Indraprasta and thus goes the cause- effect action- reaction equation of the male chauvinists.

It is the general trend of the world from times immemorial to understate and undermine the patient suffering and perpetual pangs of women. Draupadi's case too is not different. Draupadi, in actuality, is the last word for feminine suffering but the intensity of her pain is trivialized by attributing those 'womanified' vices to her. M.T's Draupadi is envious, opportunist, vain, luxury-crazed, and a notorious power-maniac. Thus, when she is being shared on bed and later forced to share Arjun and Bhima with Subhadra and Balandhara respectively, her grief is never given ventilation and if she suffers, it is portrayed to be a well deserved thing. As in the words of Baladhara, "I doubt if she even saw me properly. I think she may have seen me as a shadow when she looked at something in the distance" (109).

M.T diagnoses Draupadi with fierce addiction for power. Though he promises of not altering the basic frame work built by the first Vyasa, M. T's frequent instances of keeping silence betray his defying that claim. In an instance where Yudhishtir makes the clear suggestion that let Bhima be the next king, but later he himself gets ready for being anointed with royalty. What happens in between is mystery. But M.T is arrested by his own statement that a story writer is obliged to do; decode the cryptic aspects behind the organic growth of the plot. Subsequently he puts the blame on mother Kunti and the much sinned against, Draupadi, women, no doubt, are always at the receiving end. Vyasa's silence is clearly transformed as the fatal weapon against womanhood and its dignity. It is with clear set of prejudices that M.T approaches the character of Draupadi: "Taking into consideration the stability of her own position, Draupadi- an expert in argument- could not have remained silent" (introduction 17).

M.T dedicates volumes to muse on the unjustifiable eagerness on the part of Draupadi to maintain her queenly glory. Those eyes that witnessed the bloody deaths of sons and grandsons seem to give out a greedy glow when they come across the grandeur of power. Bhima himself stigmatizes Draupadi on this account. As in the words of Bhima; "Right across us was Draupadi on the seat for the royal consort. I noticed the fragrance of the sandalwood paste and the rustle and glitter of the silk dress. She was supremely satisfied. No recollection of her dead sons bothered her now" (242). When referring to the story of vidula, Kunti says that fruitless love is fit for a female ass only; it actually fortifies M.T's argument. However M.T is unpardonably blind towards a different version of Draupadi in which she wholeheartedly accompanies her husbands to live in the limited comforts of the forest. This Draupadi is a perfect antithesis of the queenly figure drawn before that falls head over heels

before the tempting sight of power and regal luxuries. Unfortunately, M.T prefers the second one to the one that voluntarily takes on the part of difficulties and sacrifices out of love. It must be surmised that M.T alarmed by the possibility of Draupadi winning the considerate attention of readers hence her portrayal as a disgustingly nagging wife who torments her husbands with a series of complaints and silly grievances.

Draupadi, according to M.T, is an indelible blot on the dignity of wifehood. She fails to discern the depth of Bhima's unconditional love. Again as a wife, she makes the most cunning use of her husbands in order to achieve her goals. But what else can she expect from those spineless structures that could not even save her honour even the cruelly smitten Bhima sat tongue-tied in the gallery, spectating his sweet-heart being peeled off till the divine intervention comes to the last minute rescue. Draupadi when follows her husbands into the darkness of the forest, presents herself to be the true devotee of dharma, but this lady who treads thorny paths because of her power-lusty husbands is invisible to the chauvinistic eyes of the author or rather he never takes pain to overcome this blindness imposed by gender bias.

Conclusion

All those attributes with which the passing years has bedecked womanhood are meticulously observed and taken up by M.T and he makes the optimum use of them within his Second Turn while moulding his own version of the much misunderstood character of Draupadi. Through a series of overt and covert attacks launched against womanhood, M.T becomes the chief figure among the numerous spokespersons of a male dominated society. M.T's Draupadi is a microcosm of the female world in the masculine perspective. As in the essay "'The Blank Page' and Issues of Female Creativity," Susan Gubar states that male writers often use literature as a way to create women the way they would like them to be in real life; women are the "blank page" upon which the male writer pens down his prejudices. In other words, the female in fiction is an incomplete being until the male author shapes her with his patriarchal chisel. This insensitive attitude of labeling the female as a 'blank page' shuns her in life and literature.

References

1. Barrett, Michele. "Ideology and the Cultural Production of Gender." *Women's Oppression Today: The Marxist Feminist Encounter*. London: Verso, 1998. Print.
2. Dandekar, R.N. *The Mahabharata Revisited*. New Delhi: Sahitya Academy, 1990. Print.
3. Gardiner, Judith Kegan. *On Female Identity and Writing by Women*. Ed. Elizabeth Abel. Chicago: The University of Chicago Press, 1980. Print.
4. Gubar, Susan. "'The Blank Page' and the Issues of Female Creativity." *Writing and Sexual Difference*. Ed. Elizabeth Abel. Chicago: The University of Chicago Press, 1980. Print.
5. Nair, M.T Vasudevan. *Second Turn*. Trans. P.K Ravindranath. Chennai: Macmillan India Ltd., 1997. Print

“Waiting” For The Barbarians?!: A Study Comparing The “I” in *Waiting For Barbarians* With “Kurtz” in *Heart Of Darkness*

Abstract

J. M. Coetzee is one of the famous writers of the twentieth century whose mission in writing is to redefine many of the aspects we now brand as colonial and postcolonial. His early writings were primarily against colonialism and racial discrimination. His works after the 1990s share with the readers the postcolonial experience of the newly freed South African Republic with all its teething troubles. Coetzee’s mission is to find a universal nature to many of the present day phenomena like colonialism, post colonialism, imperialism, independence, new republic, militarism, exploitation, power craze and neo colonialism. Coetzee is an external examiner or reporter of the world scenario whose observations help the reader to either subscribe to his viewpoints or draw his own. Coetzee can be considered a success in writing as an observer of global issues. Bernard Levin considers that “Coetzee knows the elusive terror of Kafka” (np.). His writing is often pointed and even though it is not directed to anybody in particular it often finds its mark which is basically the megalomaniac rulers of the world. As Africa is a continent with a number of coup d’états and such megalomaniac rulers, Coetzee is never at a loss to get sufficient examples to prove his theories. The violent history and politics of his native country, especially apartheid, has provided Coetzee much raw material for his work, but none of his books has been censored by the authorities. Often he has examined the effects of oppression within frameworks derived from postmodernist thought. Coetzee’s reflective, unaffected and precise style cannot be characterized as experimental, but in his novels he has methodically broken the conventions of narration.

Introduction

Waiting for the Barbarians is a novel published in 1980. Nadine Gordimer commented on it thus:

J. M. Coetzee’s vision goes to the nerve centre of being. What he finds there is more than most people will ever know about themselves, and he conveys it with a brilliant writer’s mastery of tension and elegance. (blurb).

Dr. Appu Jacob John
Department of English
St. Albert’s College, Ernakulam

The Listener commented that:

Waiting for the Barbarians is a book with the frightening clarity of a bad dream. It is powerful and provocative, and the author's evident anger and pity are not allowed to turn a subtle work of the imagination into a political pamphlet. (blurb).

The book is a bold yet general survey of the colonial situation all over the world. Coetzee tells us about an unnamed empire whose distant frontiers are supposedly suffering from a threat from outsiders who are branded as "Barbarians" by the authorities. The authorities have never seen a barbarian before but they firmly hold the belief that the latter are a constant threat to their existence. So the imperial capital sends a section of the Royal Militia under a Colonel, who hides his true self and poses as a different person before others. They torture all and are not able to find any trace of an aggression from the poor, illiterate "Barbarians". The military men go in search of their barbarian adversaries and are absolutely unable to find any of them. Their lack of knowledge of the adverse conditions of the land and of the nature of the people causes them to fail in their mission and thus unleash a period of unrest in the land. Peace is restored in the frontier province after many days of trouble when they find that the "Barbarians" are not a threat to them.

These incidents happen in an imagined fairyland but there are real life models who are like the "I" or the protagonist in *Waiting for the Barbarians*. If a careful study undertaken one can find many texts related to Coetzee's narrative. One such text is *Heart of Darkness* by Joseph Conrad. It can also be read as a sequel to *Waiting for the Barbarians*. Joseph Conrad was one of the greatest novelists of the Victorian era. His novels through their unique adventures lay bare the mind of the English youth for the close examination of the readers. He was a naturalised Englishman with an aristocratic Polish origin. One of the major faults with his novels when viewed in the modern day context is that they often are "armchair travelogues". Even when he was an official in the merchant navy travelling from place to place his novels lack authenticity. He is often considered as a writer favouring colonialism due to his aristocratic background. Many of his admirers call him "the Polish-born English novelist and short-story writer, a dreamer, adventurer, and gentleman". In his famous preface to *The Nigger of the Narcissus* Conrad crystallized his often quoted goal as a writer:

My task, which I am trying to achieve, is by the power of the written word, to make you hear, to make you feel - it is, above all, to make you see. That - and no more, and it is everything. (iii).

Among Conrad's most popular works are *Lord Jim* and *Heart of Darkness*. Conrad discouraged interpretation of his sea novels through evidence from his life, but several of his novels drew the material, events, and personalities from his own experiences in different parts of the world. Being an official in the Merchant Navy, Conrad sailed to many ports of the world, including Australia, those in the Indian Ocean, Borneo, the Malay states, South America, and the South Pacific Island. In 1890 he sailed in Africa up the Congo River. The journey provided much material for his novel *Heart of Darkness*. However, the fabled East Indies particularly attracted Conrad and it became the setting of many of his stories. While making his first voyages to the West Indies, Conrad met the Corsican Dominic Cervoni, who was the model for his characters filled with a thirst for adventure.

Heart of Darkness was based on a four month command of a Congo River steamboat, but in the novel the experience becomes analogous with a quest for the inner, eternal truth. Conrad gave Marlow his boyhood dream about penetrating into the heart of the continent. In the mid-1870s Henry Morton Stanley made his legendary journey up the Congo River to find the great missionary David Livingstone, funded by the National Geographic Society. His experiences and revelations of the commercial possibilities of the region had resulted in the setting up of a trading venture. The accounts of Commander R.H. Bacon, who travelled in Benin, described the horrors of Africa: "... everywhere

death, barbarity and blood, and smells that it hardly seems right for human beings to smell and yet live!” (np.). These two texts were influential in the writing of *The Heart of Darkness*.

One major fault of *The Heart of Darkness* is its artificiality. To justify this Conrad himself writes in *The Heart of Darkness* “We live, as we dream – alone”. Here he clearly justifies himself interpreting his dream. The narrator, Marlow-who perhaps is not so reliable-depicts to his friends a journey in Africa, where he becomes curious about a man called Kurtz. Marlow works for a company that is only interested in ivory and he witnesses the suffering of the native workers. He goes on a journey to reach Kurtz, an agent whom Marlow expects by his reputation to be a “universal genius,” an “emissary of pity, and science, and progress, and devil knows what else”. As they near the inner station of the company, they are attacked, and Marlow’s helmsman is killed. At the station they meet a Russian who idolizes Kurtz. Marlow finds a man who has made himself the natives’ god and who has decorated the posts of his hut with human skulls. Marlow tries to get the seriously ill Kurtz away down the river, but Kurtz dies: “He cried in a whisper at some image, at some vision - he cried out twice, a cry that was no more than a breath – “The horror!The Horror!” (89). Back in Europe Marlow lies to Kurtz’s fiancée, that “the last word he pronounced was - your name” (94).

In Conrad we see people hunting down Kurtz or another “I” for deserting or associating with the enemies. Marlow, the one who goes in search of Kurtz here is the benevolent version of Colonel Joll in *Waiting for the Barbarians*. There is one problem faced by *Heart of Darkness* - a problem faced by almost all the novels of Conrad. The novels of Conrad start as an anti-colonial venture, but in the end they tend to represent a colonial set up or the victory of the colonists over the colonies. Kurtz here is very much similar to “I” in his treatment of the natives. The aim of this study is to compare and contrast the “I” of *Waiting for Barbarians* with “Kurtz” in *Heart of Darkness*. This equation becomes significant because it helps in finding and analysing many of the universal elements of colonialism and imperialism present in both of them.

Waiting for the Barbarians=Heart of Darkness

Irving Howe in his essay “A Stark Political Fable of South Africa” and David Atwell in his essay “Reading the Signs of History: Waiting for the Barbarians” argues that the entire landscape set by Coetzee is a mythological sphere by which he wants to prove some “universal facts”. In fact what Irving Howe finds is that these universal facts and truths about colonialism, aggression, imperialism and slavery are what we find in almost all parts of the world. Coetzee through a number of well-framed metaphors tries to produce a universal platform to discuss these ideas. What is the purpose for which Coetzee has produced such a tale? Irving Howe answers this as

Mr. Coetzee tells the story of an imaginary Empire, set in an unspecified place and time, yet recognizable as a “universalised” version of South Africa. This allows Mr. Coetzee some esthetical distance from his subject, for even while remaining locked with the history of his moment, he isn’t completely at the mercy of its local chaos and ugliness. The result is a realistic fable, at once stark, exciting and economical. (np).

This idea of universalisation of the basic realities of colonialism, aggression and slavery is seen throughout the novel. Being a South African and a Boer or person of Dutch descent Coetzee is quite conversant with these facts. Coetzee is a member of the colonised community while the “I” or the magistrate is from the coloniser community. The tale becomes once more interesting and universalised, as all the characters except Colonel Joll and his henchman Mandel have no names. They are just mentioned as “I”, “the girl”, “he”, and “she” or by specifying the various interpersonal relations. By doing this Coetzee makes the story happen anywhere on this earth. The coloniser in both the tales becomes the colonised as the tale progresses. So the study becomes interesting since both the books have many similarities.

In *Heart of Darkness* the hunt for Kurtz starts as the search of the coloniser for a deserting official. A number of people take part in the search. None of them clearly knows him. He is a mystery to them. At first all blame him as a thief stealing the company's wealth. Only Marlow is somewhat conscious about the mental status of Kurtz. He makes allowances for Kurtz's behaviour as being the result of his secluded life in the distant colony far from his peers. In the end even after Kurtz is killed, Marlow is still puzzled trying desperately to come to terms with Kurtz's life as a company official and as a tribal chief.

Equating "I" to "Kurtz"

The Magistrate of one of the towns of a fabulous empire - "a responsible official ... serving out my days" - is Coetzee's unnamed central character. This magistrate or "I" - as he is narrating to us his story - is the key character in *Waiting for Barbarians*. Irving Howe comments that

The Magistrate's voice, the voice of a moderately corrupt yet not brutal man who surveys his realm with a lax good nature, fills out the book in an unbroken present tense. This Magistrate serves two purposes, as the eye that sees the action and as a voice that comments. (np).

The story is about the life and times of "I" the Governor of the frontier province of the empire. For years under the wise leadership of "I" the frontier province existed in a peaceful state. Those on the other side of the border are known only as "Barbarians". The questions about the early life of "I" about his family, friends etc. are not discussed. The only known fact about "I" is that he has been the governor of the frontier province for years. The "I" has a very loose character and he is attracted to the Barbarian girl. He cares for and caresses the girl. But his real motive is under suspicion. People tend to think that his primary intention was to seduce her.

Dominic Head in the essay "An Ethical Awakening: *Waiting for the Barbarians*" from his book *J. M. Coetzee* says that

His (magistrate's) unquestioning faith in judicial procedures, his refusal to doubt guilt, the association he perceives between pain and truth/ enlightenment, his fascination for the tortured body – these are all factors in the novel's analysis of Empire. (np).

This is surely the correct picture of the "I" in the first part of the novel. The affinity towards torture and torturing others is an interesting aspect we see with reference to the colonists.

"Kurtz" is not always a comparison to the "I". Kurtz can be considered as an equivalent to the "I" or magistrate after his persecution. Kurtz is a mystery while the magistrate is a clear character. Kurtz has experiences similar with those of the magistrate. The reason why Kurtz joined the other side is not clearly defined. He leaves Marlow and the readers in a state of bewilderment. They are unable to really understand the true state of affairs. Marlow is not able to judge according to the situation, as he is the Imperial Law's servant.

The Milieu

The landscape in Coetzee has a mixture of all kinds of climate like the prominence of the four seasons, complex yet coexisting landforms like deserts, snow-capped mountains, rivers, riverbeds and valleys. No other type of animal except some domestic ones, are mentioned in the book. On the whole, Coetzee concentrates in the book on man as an object for thorough study and makes his novel an authorised text which the readers keep on remembering long after they have completed reading it. Such a presentation fulfils his intention to highlight that all this can happen anywhere in the world. Thus Coetzee once again draws our attention to the universality of colonialism.

The story of *Heart of Darkness* is believed to take place in the Congo. Many critics say that young adventurous Conrad was for some time the Captain of a steamboat in the Congo. Memories

about the primal life of people and pristine nature might have influenced Conrad's writing. Marlow, Captain of the "Nelly", describes each bend and current of the Congo River precisely. This precision is due to the writer's own experience. The only aim for all the characters in *Heart of Darkness* is to catch Kurtz. So there is no mention of any of them showing any interest in the colonised cultures. Kurtz' interests are not revealed by the author.

"Waiting" for the BARBARIANS?!

The term "Barbarian" is used by Coetzee to denote the unknown "neighbours" of the nameless empire. This term has a derogatory meaning in colonial parlance. The colonisers who considered their culture superior to all other cultures claimed themselves to be elite and the colonised as barbarians or uncultured people. This they boasted without having any idea about their culture. This was done as part of the colonial propaganda agenda and their intolerance towards other cultures. This is the same attitude we see in Macaulay's *Minute on Education*; classifying ancient Indian wisdom as silly old wives' tales. This is the same attitude we find in the Spanish conquistador Pizarro's journals. This is the same attitude we find in many slavers of the Africa and the conquerors of the East. This can also be considered a representation of perverted Occidental mentality, which later came to be known as the "White Man's Burden" to civilize the whole world. The use of the definite article "the" in the title once again thoroughly says the status of the "Barbarians".

The most ironic thing in their attitude towards the colonised is that many of them considered their colony like India as the "Jewel in the Crown"; even though they considered the natives and their culture as "Barbarian". An authentic fact about the "Barbarians" is that it is their fruits of labour that the colonisers enjoyed. In fact the sweat, blood, toils and tears of these "Barbarians" have made all the great empires in the World. The title of the novel referred to a poem by Constantine Cavafy: "and now, what will become of us without /barbarians? /These people were a kind of solution" (3). David Atwell comments on this as

In the poem by C. P. Cavafy of the same title as the novel, the barbarians enable the Empire to array its forces, reconstitute its hierarchies, displays its symbols - in short, to refurbish itself as a complete political and semiotic system. When, in the poem, the enemy does not materialize at the city gates, the Empire's nervous pleasures of anticipation quickly lead to confusion and despondency. (np).

The "Barbarians" of Coetzee have a mystic nature. No one knows their true identity and their existence. The reader is given only certain hint that once there existed a great barbarian civilization. Barbarians are a simple, peace loving folk who are made a national threat by the "Third Bureau" or the military intelligence who make mountains out of molehills. Such an attitude is actually a camouflage for the colonising mind-set of the empire and its bureaucrats. This is what is happening in Iraq and Afghanistan these days.

There is another set of people called the "fishing folk". They are very much marginalized. They can be considered as the representations of ancient tribal cultures. They lack good leadership and therefore are unable to resist the oppressor who tortures them without any qualms. Their crops are burned, their huts destroyed and their life ruined.

In *Heart of Darkness*, the natives are considered barbaric by the way they are presented. His presentation makes them look more barbaric than anyone else. Conrad effectively evokes a dream like image of the jungle by using strong words to describe the natives' appearances, characteristics and presumed behaviour. Very common in his descriptions are the use of very strong and passionate words like "wild" and "intense". For example the description of a boatload of natives paddling downstream is distinctly primitive. He says: "they shouted, and sang... their bodies streamed with perspiration; they had grotesque masks...but they had bone, muscle, a wild vitality and intense energy of movement..." (40).

In contrast a comparison with the author's description of a white, affluent, suggestively desirable race, make them appear artificial, sloppy and lethargic; clearly seen is the following phrase, "flabby, pretending, weak-eyed devil of a rapacious and pitiless folly".

Another obvious implication of a primitive and savage culture which gives the reader the illusion of wildness is the author's use of the word "cannibals". By using the word cannibal the author implies a savage and uncivilized race, since both the word and the act are abrasive especially in the context of the period in which this text was written in 1900's. Back then the idea of natives in the jungle was a proven fact not a rumour or fantasy. Already afraid of this reality the use of the word made the image of the native more frightening and convoluted, whereas today, cannibals are hardly a threat at all since the likelihood of their existence is purely fiction.

The action of "Waiting" too is another fact that is confusing. "What/whom are they waiting for" is the immediate question. We can say in a rough manner that they are waiting for the Barbarians. But in reality are the Barbarians going to attack the empire? Coetzee does not ever tell us that they are going to attack. Instead he only gives some allusions that they are a peace loving people. The Army retreats but still the people have fears about what is going to happen. They are tense but in the end they find that they are waiting for nothing. This new knowledge somehow becomes old as they have adjusted to their new realities. The cover page of the Penguin edition of *Waiting for the Barbarians* has a picture of a boy setting up scarecrows dressed up in soldier's uniform on top of the frontier town's walls. This picture depicts how the "waiting" has become ritualistic. This ritual too has found a place in their daily life. They are like Vladimir and Estragon waiting for Godot in *Waiting for Godot* by Samuel Becket. This sort of a waiting also exists in our everyday life; we as a nation are lying in wait for all types of barbarian or enemy aggressions. In that sense the novel is also a satire against the mad arms race conducted by various nations in our world.

As concluding remark one should say that it is actually Colonialism and Imperialism that made people Barbarians, first by branding innocent peace loving people as Barbarians, second by denying their indigenous cultures and forcefully making them adopt the coloniser's ways, third, even after giving them independence, by dumping their unwanted articles to the colonies and by starting a neo colonial system. Good examples of this are the civil wars raging throughout the world. If we examine their causes it is generally for power-an indigenous attempt to imitate the Western coloniser!

The Girl

"The Girl" another nameless character is the heroine of the story. "The Girl" is in a sense the cause of all the sorrow. "The Girl" is the image of the colony. The magistrate's care for her is the pretext with which all the colonisers start their venture. Theirs and the magistrate's true desire are to sexually abuse her. This sexual abuse is the image of the drain of the colony's wealth into the coloniser.

The girl is injured and is a barbarian. The first problem in the magistrate's caressing her is that he is going against the colonial notion. The magistrate or the representative of the imperial government should not care for a Barbarian especially since they are enemies. The magistrate goes one step further as he goes out to make contact with the Barbarians. This becomes even graver as he is betraying his parent country. These are the two charges levelled against him.

The girl is an inimitable character. She is a character found only in *Waiting for the Barbarians*. *Heart of Darkness* on the other hand is the search for a culprit. The colony here is the ultimate source of wealth. So anybody who is stealing the wealth of the colony should be prosecuted. The fact that the coloniser himself is the chief robber of the wealth of the colony is conveniently forgotten. This is the mission of Marlow, to capture and execute the thief. Here the colony is viewed as a vast mine of resources and the natives, to whom all these wealth should go, as mere savages.

The Third Bureau

The name “Third Bureau” sounds similar to the German “Third Reich” of World War II. What makes the Third Bureau to come to “I”’s empire was the news about two imperial horsemen found dead strapped onto their mounts. There is no sort of an enquiry about the death. Instead it is considered as a warning from the barbarians. A Colonel Joll, who always hides his eyes behind dark glasses, heads the section of the bureau that comes to the town. The name too sounds odd and unfamiliar. What Coetzee thus achieves is the universalization of militarism. The name “Joll” and the descriptions in the first chapter give the readers a picture of a jolly person. But Joll is jolly only when he is pursuing the ordinary barbarians. Joll and his henchman Mandel, a name similar to the word “mental”, subject various barbarians to different types of torture. The novelist gives a constant reminder of this throughout the novel by mentioning the soot left on the wall of the barracks, which had been used as the torture room. Colonel Joll brushes aside the possibility that the barbarians may be innocent of any revolutionary plans. There is a remarkable description of how he conducts an interrogation:

First, I get lies, you see -this is what happens - first lies, then pressure, then more lies, then more pressure, then the break, then more pressure, then the truth”. Or as the Magistrate sardonically restates the torturer’s creed: “Pain is truth; all else is subject to doubt. (36).

Unable to control the emissaries of the Third Bureau, the Magistrate wants to dissociate himself from their methods even as, in all honesty, he has to admit that he and they are both servants of the Empire. Later the Bureau tortures the magistrate himself alleging an allegiance between the barbarians and the latter. He is imprisoned in the same barracks room where the barbarians had been interrogated. He is reduced, through humiliation and torment, to a subhuman level. This is described in the book as

When (the torturers) first brought me back here ... I wondered how much pain a plump comfortable old man would be able to endure in the name of his eccentric notions of how the Empire should conduct itself. But my torturers were not interested in degrees of pain. They were interested only in demonstrating to me what it meant to live in a body, as a body, a body which can entertain notions of justice only as long as it is whole and well, which very soon forgets them when its head is gripped and a pipe is pushed down its gullet and pints of salt water are poured into it. ... They came to my cell to show me the meaning of humanity, and in the space of an hour they showed me a great deal. (38).

The torture is dubbed under the name of humanity and is an eye-opener as to what it means to be a man and to suffer endlessly. The cruelty becomes so cruel that even those who have not done the crime are forced to confess to the charge rather than endure any more. The torture makes the “I” or the magistrate; “the plump old man” (his own words) a haggard old man. However, even with all these tortures they are unable to break the magistrate’s will. He becomes an epitome of a one man resistance to the empire. The Third Bureau sends troops into the land beyond the frontiers of the Empire in order to seek out and destroy the enemy. At first, reports of victory; then, a nervous silence; finally, the troops return, dazed and bedraggled. The so called enemies have defeated them. Coetzee describes the defeat in this way.

We were not beaten, ... (the barbarians) led us out into the desert and then they vanished! ... They lured us on and on, we could never catch them. They picked off the stragglers, they cut our horses loose in the night, they would not stand up to us! (40).

Colonel Joll and his men retreat; the Magistrate resumes his old authority. The Empire fades; the barbarians remain. The fear of enemy attack is still in the air but a bit subdued now.

The Influence of other Characters

The most important minor characters of the novel are the residents of this frontier town. The residents are constantly haunted by the fear that the barbarians are going to attack. But the fear of such an attack is limited only to words because the barbarians are a wandering tribe never staying long enough to establish any claims. The Third Bureau soldiers under Colonel Joll are the true barbarians for they have destroyed the routine of their lives. Colonel Joll stokes the tiny spark of fear in the minds of the people with regard to the barbarians so that it blazes out in anger and suspicion towards the latter.

Another character who should be mentioned is the little boy who brings food to the magistrate when he is in the prison. The boy is presented as a ray of hope in the midst of adversities. He brings some sort of happiness to the magistrate, but the boy is afraid of the magistrate. He can be considered as the personification of the unbreakable willpower of the magistrate; the silver streak in the midst of the darkest tortures. The servant girls are an image of the ordinary public who are silent about the present status of the magistrate. Earlier the magistrate sexually used them. The girls were silent then too. So they once again clearly represent the ordinary public who are forcefully kept silent.

In *Heart of Darkness*, Marlow's chief helpers are a set of people who join in the hunt for Kurtz. They are deliberate pictures of colonisers. Kurtz is a fully nationalised foreigner while Marlow, towards the end, enjoys a median position. The natives are presented here as viewers of this colonial drama. They are the silent viewers unable to do anything. As in the case with *Waiting for the Barbarians* they represent the silenced majority or the public.

Critical Analysis

According to Edward Said's *Orientalism*, the use of the term "Barbarian" is a misallocated conclusion of the Occident about the Orient. This miscalculation always exists. The Occident is always attracted to the Orient, but they never truly try to understand the culture of the Orient. One of the greatest critical aspects we see is the "Other" in all the texts. The slave-master relationship is a binary that is found throughout all of them. The Barbarians are the slaves while the White men are the masters. So the slave becomes the "Other" to the master and vice versa. The other's attempt is to question his counterpart's existence. Yet some faults can be seen here as all the three tales are told from the coloniser's angle only. The colonised are mentioned in a somewhat passive manner. The Power Politics ideas of Michel Foucault are acceptable in this situation too. Power becomes a constant matter of discussion in this struggle between the centre and the margin. The margin consists of the weaker sections while the centre is the collective centre of all power and authority. The centre takes all important decisions and controls the margin.

The tendency of the "coloniser" to consider his "colonies" as barbarous is, according to Frantz Fanon in his *The Wretched of the Earth*, a mental disability. Fanon's novel idea, "Collective Catharsis" or the purgation of colonial mind-set by a violent revolution, is not seen in any of the texts. The coloniser in all the texts is portrayed as an oppressor and the colonised as the silent sufferer of this colonial hierarchy. It can be considered as the inability of the coloniser to acknowledge the colonies as equal to him in all respects. One other aspect is that the novel becomes a representation of life. This is a view formulated by eminent critics like Benedict Anderson in his book called *Imagined Communities*. Here the "imagined community" of Coetzee becomes so real that we can link up the various colonial experiences explained in the text to other works and to other societies too.

The novel is the ideal portrayal of colonial hegemony over ordinary people. A term reworked by the renowned critic Antonio Gramsci, it means the superiority of a small group over a larger group. This is an idea also discussed in *The Empire Writes Back*, the bible of post-colonial writing. Here hegemony exists at two levels. At the first level the inhabitants of the small frontier province try to

colonise the “barbarians” or those on the other side of the frontier. This first level had physical relations and consequences. The second level is rather a cultural or mental hegemony. The few representatives of the Third Bureau make the whole people think that the barbarians are their enemies. This second level of hegemony is a more serious thing when compared to the first level. The second level creates a permanent image of hostility towards the barbarians or whoever is on the other side.

Unlike Coetzee, Conrad had no bad experiences with the colonial machinery. Conrad was a Polish aristocrat who later became a naturalised Briton. Coetzee was a Boer descendant of South Africa. The South African whites considered them and the native black population through the doctrine of “Apartheid”. What is common to both of them is the fact that they also have a diasporic status like their characters and live in a no man’s land without a proper identity. The magistrate or the “I” was staying in this far off province for many years and now he is part and parcel of that frontier town.

Conclusion

Whatever be the faults we find in *Waiting for the Barbarians*, the whole text is so interesting that the reader is absolutely captivated by the narrative. You are intoxicated with the splendour of the story. That’s as it should be. The story I have to tell is one of the most splendid ever given man for writing. It is as Conrad wrote in one of his letters to Henry James. “All creative art is magic, is evocation of the unseen in forms persuasive, enlightening, familiar and surprising.” The story is so interesting that we find only in the end that all this is the re interpretation of history. The history of the colonised in *Waiting for the Barbarians*, history of the coloniser in *Heart of Darkness*.

The plot thickens so much that the reader is kept on haunted by his role in the colonising machinery all over the world. If we use Conrad’s words it will be as he says in the *Heart of Darkness*:

The Conquest of the earth, which mostly means the taking it away from those who have a different complexion or slightly flatter noses than ourselves, is not a pretty thing when you look into it too much. What redeems it is the idea only. An idea at the back of it; not a sentimental pretence but an idea; and an unselfish belief in the idea—something you can set up, and bow down before, and offer a sacrifice to . . . (80).

It is with these words that Edward Said starts his *Culture and Imperialism*. This is the true essence of *Waiting for the Barbarians*.

In a final concluding remark Chris Swister says that

You won’t see the birth of a one-man cavalry in a Coetzee novel, guns blazing, exacting revenge on the torturous regime of the Empire. You will, however, see a man willing to suffer for what he believes in. (np).

This man of ideology - a man willing to suffer for what he believes in - is a jeopardized entity. As Switzer says he can either be Christ or a fool. But his actions are so powerful that they give the reader a thought to ponder in his mind. This dream sequence in the final analysis lays a permanent imprint in the hearts of the readers. The uncertainties are cleared and like the magistrate or the “I”; they too wake into a new world of real realities and not virtual realities.

Bibliography

1. Attwell, David. *J.M. Coetzee: South Africa and the Politics of Writing*. Cape Town: University of California, 1993.
2. Coetzee, J. M. *Waiting for the Barbarians*. London: Mandarin, 1997.
3. Conrad, Joseph. *Heart of Darkness*. London: Macmillan, 1995.
4. ———. *The Nigger of the Narcissus*. London: Macmillan, 1997.
5. *Encyclopaedia Britannica*. Chicago: University of Chicago, 1992

6. Fannon, Franz, *The Wretched of the Earth*. New York: Routledge, 1990.
7. Head, Dominic. *J. M. Coetzee*. Cambridge: CUP, 1997.
8. <http://ark.cdlib.org/ark:/13030/ft5k4006q3> accessed on 10.12.15
9. <http://members.tripod.com/~ssscott/huboluv.html> accessed on 10.12.15
10. <http://texts.cdlib.org/dynaxml/servlet/dynaXML?docId=ft5k4006q3&chunk.id=d0e30> accessed on 10.12.15
11. <http://turtleneck.net/summer01/tweedjacket/coetzee.htm> accessed on 10.12.15
12. http://www.encarta.msn.com/J_M_Coetzee accessed on 10.12.15
13. <http://www.georgetown.edu/irvinemj/english016/conrad/conrad.html> accessed on 10.12.15
14. <http://www.kirjasto.sci.fi/J.M.Coetzee.htm> accessed on 10.12.15
15. http://www.kirjasto.sci.fi/Joseph_Conard.htm accessed on 10.12.15
16. <http://www.lang.nagoya-u.ac.jp/~matsuoka/index.html> accessed on 10.12.15
17. <http://www.mural.uv.es/rosegar/critica1.htm> accessed on 10.12.15
18. <http://www.victorianweb.org/authors/conrad/conradov.html> accessed on 10.12.15

Blind towards one's past: Identity crisis in Toni Morrison's *The Bluest Eye*

Abstract

Afro American writing is a body of literature produced in US by writers of African descendents. The works produced in this genre explores colonialism, slavery, racial discrimination identity crisis of Africans who migrated to US. Toni Morrison is a widely recognized author, who gained numerous literary distinctions including Pulitzer and Nobel. She is a writer who made this genre popular. Majority of her works focus on the issues like racial identity, black feminism and colonialism. There is an urge to reclaim African ancestry in her works. She also criticizes African Americans who devalue their roots. *The Bluest Eye* is a perfect example to this. *The Bluest Eye* is a novel which depicts how black girls and women internalize white as the standard of beauty. This attitude is vividly pictured through the character Pecola. Her desire for blue eyes, affinity towards whiteness shows her denial of her past ancestry. The hopeless desire ultimately led to madness, this suggests psychological conflict she undergoes between her fulfilment of wishes and her blindness towards her own ancestral tradition.

Introduction

African-American literature is the body of literature produced in the United States by writers of African descent. It begins with the works of such late 18th-century writers. Before the high point of slave narratives, African-American literature was dominated by autobiographical spiritual narratives.. Writers of African-American literature have been recognized by the highest awards, including Nobel Prize. Among the themes and issues explored in this literature are the role of African Americans within the larger American society. Toni Morrison's novels reclaiming the past is a necessary condition of subjectivity since it restores a voice and history to those who were deprived of the awareness of both. In other words, it is a restoration of subjectivity. In a postcolonial context, reclaiming the past means more than a linear or literal recording of historical facts. Rather the process of redeeming a past requires that victim of oppression recover their effaced traditions and exhume previously buried communal memories. To enable this process, the oppressed have rallied together and acknowledged their emotional devastation and physical wounds. Toni Morrison's works are based on the postcolonial feminism in which she very skillfully

Hima S.

Guest Lecturer (English)
Kerala Kalamandalam, Cheruthuruthy
Thrissur Dist. Kerala
e.mail: himas09@gmail.com

highlighted the idea of gender, race, sex and identity and similarly she also highlights the concepts of 'talking back' and making a space among white society. Toni Morrison hence secures a very apt position among the postcolonial feminist who helped these thrice colonized black women to stand up for making their own identity. The process of past reclamation and traditional recovery: thus, a means of empowering black women against the oppressive institutions of a white culture and its impositions of white images on black girls.

In *The Bluest Eye*, Morrison challenges the Western, particularly the White, standards of beauty. As the title of the novel shows, there are some interesting perceptions about standards of beauty. She also explains that if whiteness is used as a standard of beauty, then the value of blackness is decreased. The lack of love from the Black males towards Black females and children in *The Bluest Eye* is one of the most significant themes. Morrison's emphasis in *The Bluest Eye* is on racism. Moreover, she expresses influence of racism on the Black community and family also. She examines how Black females react to the so-called White standards of beauty prevalent in the American society. In his study of Toni Morrison's stance on the issue of beauty. The novel suggests that the oppressive standard of beauty peddled by movies and advertisements ravages white self-esteem as well ... but it isn't just a matter of degree. Low self-esteem is an entirely different creature than self-hate. Morrison, in this novel, focuses on the effect of change in the status of women in American community. There are two Black communities in *The Bluest Eye*: one in the South and the other in the North. In *The Bluest Eye* Black women characters are seen to be suffering to conform to Western standards of beauty.

In this novel, Morrison deals with Black women's experience in America, their struggle for finding their personal as well as their cultural identities. Pecola prayed for blue eyes every night. She believes that if she has blue eyes, they will make her look beautiful and she believes that if she looked beautiful, someone will love her and the behaviour of others would also be different, favourable towards her. Also, perhaps, her parents' behaviour would be different with her in particular and with everybody in general. Maybe they will not fight with each other in front of her. She had prayed for one year enthusiastically without losing her hope. She sat for a long time in front of a mirror and looked in the mirror to understand what is the secret of ugliness which made her different from others, the Whites, and which made her teachers and classmates scorn her. She lives in such circumstances in which love is an adjustment effected by money, violence, dishonesty, psychological disturbances, societal disaffection etc. Morrison depicts some of these psychological upheavals as below: ...Long hours she sat looking in the mirror, trying to discover the secret of the ugliness, the ugliness that made her ignored or despised at school, by teachers and classmates alike. She was the only member of her class who sat alone at a double desk. The first letter of her last name forced her to sit in the front of the room always.... She also knew that when one of the girls at school wanted to be particularly insulting to a boy, or wanted to get an immediate response from him, she could say, 190 "Bobby loves Pecola Breedlove! Bobby loves Pecola Breedlove!" and never fail to get peals of laughter from those in earshot, and mock anger from the accused. (34) In *The Bluest Eye*, Pecola is looking for beauty and her identity.

Pecola in *The Bluest Eye* is rejected not only by White society but is also rejected by Black society as she is ugly. In Pecola's family sexual abuse and menace come from inside the family itself. In *The Bluest Eye*, Morrison deals with Black women's repression due to their blackness as it does not conform to the White standards and ideals of beauty and the so-called sophistication of the Whites. *The Bluest Eye* makes one of the most powerful attacks yet on the relationship between Western standards of female beauty and the psychological oppression of black women. , Black men emotionally and sometimes physically abuse Black women and even Black children and there is hardly any respect for Black women and Black children by their own community itself. Black men emotionally and sometimes physically abuse Black women and even Black children and there is hardly any respect for

Black women and Black children by their own community itself. *The Bluest Eye* makes one of the most powerful attacks yet on the relationship between Western standards of female beauty and the psychological oppression of black women.

Black women realize their situation and restrictions of the society put on them; however, they have positive role in their families. They look after their family, love their husbands, children and tolerate all troublesome behaviour that comes from other cultural standards and makes them appear as inferior beings in the society. Pecola prays for having blue eyes with the hope that they would change her life. "It had occurred to Pecola some time ago that if her eyes, those eyes that held the pictures, and knew the sights—if those eyes of hers were different, that is to say, beautiful, she herself would be different." The omniscient narrator states what Pecola believed, that if her eyes were beautiful then her life would be different. (46) Her prayer for blue eyes symbolizes a desire for meeting the repeated messages of White cultural superiority. She believes that the only way she can escape from this situation is to become beautiful through acquisition of blue eyes. She shares a bedroom with her brother and lives with her disabled mother and her drunken father. She is raped by her father and resultantly becomes pregnant. Her rape by her alcoholic father symbolizes the most prominent type of sexual assault against Black females by Black males and this is also the most tragic illustration of Black women's abuse as shown in the novel. She is an innocent child, but, very unfortunately, she is made to suffer from oppression of hers by the Whites as well as by her kith and kin like her father which is seen in the fact that she is made a victim of rape and domestic violence by her own father. Pecola doesn't know the meaning of love and also she could never control her body. Her sexual experiences are of just being raped by her father.

The Bluest Eye provides an extended depiction of the ways in which internalized white beauty standards deform the lives of black girls and women. Implicit messages that whiteness is superior are everywhere, including the white baby doll given to Claudia, the idealization of Shirley Temple, the consensus that light-skinned Maureen is cuter than the other black girls, the idealization of white beauty in the movies, and Pauline Breedlove's preference for the little white girl she works for over her daughter. Adult women, having learned to hate the blackness of their own bodies, take this hatred out on their children—Mrs. Breedlove shares the conviction that Pecola is ugly, and lighter-skinned Geraldine curses Pecola's blackness. Claudia remains free from this worship of whiteness, imagining Pecola's unborn baby as beautiful in its blackness. But it is hinted that once Claudia reaches adolescence, she too will learn to hate herself, as if racial self-loathing were a necessary part of maturation.

In the novel, whiteness is associated with beauty and cleanliness (particularly according to Geraldine and Mrs. Breedlove), but also with sterility. She was never able, after her education in the movies, to look at a face and not assign it some category in the scale of absolute beauty, and the scale was one she absorbed in full from the silver screen. Pauline internalized the white definition of beauty and perceived people as valuable or not in comparison. She even despised herself because she was not beautiful according to white standards. (122).

In contrast, color is associated with happiness, most clearly in the rainbow of yellow, green, and purple memories Pauline Breedlove sees when making love with Cholly. Morrison uses this imagery to emphasize the destructiveness of the black community's privileging of whiteness and to suggest that vibrant color, rather than the pure absence of color, is a stronger image of happiness and freedom. Pecola is obsessed with having blue eyes because she believes that this mark of conventional, white beauty will change the way that she is seen and therefore the way that she sees the world.

Conclusion

The black characters in the novel who have internalized white, middle-class values are obsessed with cleanliness. Geraldine and Mrs. Breedlove are excessively concerned with housecleaning—

though Mrs. Breedlove cleans only the house of her white employers, as if the Breedlove apartment is beyond her help. This fixation on cleanliness extends into the women's moral and emotional quests for purity, but the obsession with domestic and moral sanitation leads them to cruel coldness. In contrast, one mark of Claudia's strength of character is her pleasure in her own dirt, a pleasure that represents self-confidence and a correct understanding of the nature of happiness. The person who suffers most from white beauty standards is, of course, Pecola. She connects beauty with being loved and believes that if she possesses blue eyes, the cruelty in her life will be replaced by affection and respect. This hopeless desire leads ultimately to madness, suggesting that the fulfillment of the wish for white beauty may be even more tragic than the wish impulse itself.

References

1. Abrams M.H. *A Glossary of Literary Terms*. Banglore: Prism Books Pvt Ltd, 2003. Print
2. Barry Peter. *Beginning Theory*. New Delhi: Viva Books Private Limited, 2012. Print.
3. Lodge, David. *Modern Criticism and Theory*. Longman, London, 1983. Print.
4. Morrison Toni. *The Bluest Eye*. Vintage –Penguin Random House. UK. 1994. Print.
5. Waugh, Patricia, ed. *Literary Theory and Criticism An Oxford Guide*. New Delhi: Oxford UP, 2006. Print.

Cross cultural Identity: Jhumpa Lahiri's *The Namesake* as a Novel of Indian Diaspora

Abstract

Diaspora writers continue to be hung up on their national identities even if they may not sometimes be aware of admit it themselves. The question of identity and the dynamics of relationship affect these writers. The writers reflect, analyze and criticize that particular environment and the world around them even when they does not belonging to it. The expatriate writer lacks a shared memory which is often the basis of writing in one country. Jhumpa Lahiri, the Indian diaspora writer, in her maiden novel *The Namesake* presents the cross cultural identity and crisis of expatriates. The novel has an American setting; still India continues to form part of her fictional landscape. As most of her characters have an Indian background, India keeps cropping up as a setting, sometimes literally, sometimes more figuratively in the memory of the characters. The Protagonist of the novel Gogol is a second generation Indian-American, where as his parents Ashima and Ashoke being the first generation lives in a world of memory and suffers identity crisis. They long for their root and thus strictly follow their rituals and finds consolation from it. The present paper is an exploration of Jhumpa Lahiri's celebrated novel *The Namesake* as a novel of Indian diaspora. The paper also focuses on the problem of accommodation and adaptation faced by almost all expatriate characters in the novel.

Key words: Diaspora, Cross cultural identity, Dislocation, Alienation, Displacement

Introduction

Most societies today are multi-cultural societies and the writers living and writing in such a society is affected at multiple levels by both the cultures. Such a writer is constantly in a state of flux. The writer may feel no crisis of identity or alienation or depression especially if one is a second-generation expatriate. The writing of expatriate writers is generally termed as diasporic writing. The word diaspora is derived from the Greek for 'scattering of seeds'. It is used to describe population migration and dispersal. Originally the term is used to refer to the Jewish peoples forced exile from Israel in the Pre-Christian era and their subsequent removals from Spain, Portugal and Russia, where they had resided for well over a thousand years. Now it refers to virtually any mass migration. According to the critic Silky Khullar Anand, the

Febina.T.P

M. Phil. Research Scholar
Department of Studies in English
Kannur University, Kerala
e.mail: febina0490@gmail.com

term has come to mean any sizable community and sharing nation living outside its own country and sharing some common bonds that give them any ethnic identity and consequent bonding (87). Today there are over twenty million people of Indian origin spread across a hundred and ten countries. Dislocation was something which ought to generate angst, thus the writers revealed the angst and pain through their writings.

The literature of Indian Diaspora produced by writers of such diversity, as V.S. Naipaul, Salman Rushdie, Anita Desai, Kavita Daswani, Kiran Desai, Shauga Sing Baldwin, Uma Parameswaran, Bharati Mukherjee, Rohinton Mistry, Chitra Divakaruni, Meena Alexander, Jhumpa Lahiri, Meera Syal, Abha Dawesar, Suniti Namjoshi, Rishma Dunlop, Naita Rau Badani and many others, explore problems and possibilities engendered by the experiences of migrancy and diasporic life. In the process of engaging and negotiating notions of history, identity, gender, and cultural and racial purity the works of these writers debated with the suffering of migration and displacement. As a body of literature it represents an important multicultural perspective within individual, nation literature as well as a more global perspective, taking in the phenomenon has consequently led to the emergence of a new narrative of travel, dislocation, displacement and uprootedness. Indian diaspora literature in English problematizes the concepts of assimilation and acculturation in exploring the experiences of diasporic life by concentrating on multiple aspects of life in exile.

Jhumpa Lahiri, the diasporic writer, was born in London and grew up in Rhode Island, travelled several times in India and lives in Brooklyn. She belongs to the category of writers who have 'inherited a sense of exile'. They are identified more in the American tradition than in the field of Indian writing in English. In her writing she addresses the themes of immigration, collision of cultures, conflict in relationships, anxiety of migration, feelings of homelessness and crisis of identity- both American/ Indian. Pulitzer Prize winner for the year 2000, Jhumpa Lahiri can be categorized as a multi-cultural, diasporic, post-colonial, marginal, South Asian women writer. As an expatriate, Lahiri stands at an interesting border of the cross-road of culture. The space of the exile in almost all of her works presents the pain of both longing and loss. Each one of her protagonists persistently had the feeling of being the 'other' –not American enough, not Indian enough, stretching between identities.

The Namesake is the story of Gogol, named after Russian novelist Nikolai Gogol. Gogol experiences the ambivalence of his parents who have not yet been able to be assimilated into the new land. A constant combination of distance and intimacy binds them to their native city of Calcutta which to Lahiri seems to be 'a vast, unruly, fascinating city'. Ashoke and Ashima Ganguli and their children Gogol and Sonia are all exiles –who in quest of an ideal world are constantly juggling the experiences of this family, which is sometimes afflicted with a feeling of cultural alienation: diaspora both literal and metaphorical, referring both to the physical displacement as well as the shaping of different sensibility. Lahiri presents evidence for the feeling of disorientation associated with immigration through subtle details that emphasize the cross cultural differences.

The novel is a tale of immigrants, Ashoke and Ashima Ganguli, who come from India and settled in America, but keeping their own traditions intact. *The Namesake* refers to Gogol, their first born, who finds a conflict with his name. It is Nikolai Gogol; the Russian writer inspired Ashoke Ganguli to Christian his son as Gogol. Nikolai Gogol (1809-1852), considered as the main influence in the development of nineteenth century Russian realism. He was distorting to an extraordinary power of imagination and an intense, expressive verbal style. Gogol succeeded in expressing an optimistic vision of life. Ashoke Ganguli, impressed by the vision of life expressed by Nikolai Gogol and thus named his son. Gogol Ganguli grows up at first by accepting his name, but later rejecting it to the point where he changes it legally as an adult. Gogol's name represents his father's hopes for a bright future, stemming from a massive train wreck that Gogol's father survived. A turning point in Ashoke's

life, it is this tragedy that shapes his future family's life, taking him to America a few years later, bringing back with him to this foreign land his wife Ashima. Throughout the novel, Gogol is haunted by his name, and thus he changes it to Nikhil he realizes that cannot get away from it. The name seems to make him stand apart from the rest of his classmates:

Though substitute teachers at school always pause, looking apologetic when they are at his name on the roster, forcing Gogol to call out, before even being summoned 'that's me', teachers in the school system know not to give it a second thought. After a year or two, the students no longer tease and say 'giggle' or 'gargle' (66-67).

The novel can be considered as a Bildungsroman as it describes the story of Gogol's life: his childhood, spent mostly in the US, with occasional long trips to India; his college career, at Yale and Columbia, where he becomes an architect; several love affairs – in college with an American girl, then a strange sort of affair, including living together, with a very privileged American; then an affair with a married woman; and finally a semi-arranged relationship followed by marriage to another Indian – a girl he had met as a child. Gogol is a fully realized character, and very much an American born in the US with an identity split between his Indian heritage and his American life. As for the colonial and postcolonial West, India is a mysterious land for the Ganguli family. The young ones cannot adjust with the situations of India. They are surprised to learn that their father has planned a trip for them, first to Delhi to visit an uncle, and then to Agra to see the Taj Mahal. It was Gogol's and Sonia's first journey outside of Calcutta, their first time on an Indian train. They depart from Howrah, the immense, soaring, echoing station, where barefoot coolies in red cotton shirts pile the Ganguli's Samsonite luggage on their heads, where the entire families sleep, covered in the rows of the floor. Gogol is aware of the dangers involved: his cousins have told him about the bandits that lurk in Bihar, so that his father wears a special garment under his shirt, with hidden pockets to carry cash, and his mother and Sonia remove their gold jewels. On the platform they walk from compartment to compartment, looking for their four names on the passenger list pasted on the outside wall of the train. They settle on to their blue berths, the top two swinging down from the walls when it is time to sleep and held in place by sliding latches during the day. A conductor gives them their bedding, heavy white cotton sheets and thin woolen blankets. In the morning they look at the scenery through the tinted window of their air-conditioned car. As a result, the view, no matter how bright the day was gloomy and gray. During their journey Ashima and Ashoke could manage with their broken Hindi. But Sonia and Gogol are forced to demand for English. Like Gogol and Sonia their parents too had a feeling of identity crisis and problem of belongingness in their own land.

There are three types of migration: forced migration, partially forced migration and voluntary migration. Ashoke was moved to America with his own interest. In this diaspora under consideration here, there is no external compulsion, no large scale migration. The emigration of Lahiri's parents as well as of Gogol's father in *The Namesake* has to be understood and analyzed in the context of the 'brain drain' that worried many countries of the developing and under developed world. Ashoke goes to America as a research scholar and a professor of science at MIT. When Ashoke moves to the US he is actually fleeing from the terrible experience of a train accident and is inspired by the memories of a chance encounter with Ghosh, a pot bellied middle aged Bengali business man who returned to India after two years in England. Ghosh comes back to India because his wife was inconsolably miserable abroad but yet Ghosh speaks reverently of England:

The sparkling empty streets, polished black cars, the rows of gleaming white houses, he said were like a dream. Trains departed and arrived according to schedule, Ghosh said. No one spat on the sidewalks. It was in a British Hospital that his son had been born (15).

As an immigrant Ashoke would have to confront social mores totally alien to him and attempts to come to terms with this new cultural and social world. Ashima becomes lonely in the alien land. She longs to return her home with her child. Her desire to be with her parents is realistically portrayed in the novel:

...on her own with Gogol for the first time in the silent house, suffering from a sleep deprivation far worse than the first of her jet lag, (Ashima) sits by the three sided window in the living room on one of the triangular chairs and cries the whole day. She cries as she feeds him, and as she pats him to sleep, and as she cries between sleeping and feeding. She cries after the mailman's visit because there are no letters from Calcutta. She cries when she calls Ashoke at department and he does not answer. One day she cries when she sits in the kitchen to make dinner and discovers that they have run out of rice (34).

With the experience of living in a foreign country, like all other characters Ashima has changed from an ignorant innocent woman to a woman who can travel alone. For her it is a journey of life.

Conclusion

Jhumpa Lahiri's celebrated work *The Namesake* is a novel that explores diasporic concepts of cultural identity, rootlessness of tradition and familial expectations. As the title suggests the crisis of identity begins from the name of the hero of the novel. The novel is a cross cultural, multigenerational story of a Hindu Bengali family's journey to self-acceptance in Boston. In Sireesha Telugu's view it is also a restoration and combination of both the cultures with a mixture of rice crispies, planters peanuts and chopped red onions with a mixture of salt, lemon juice and pepper. This signifies Ashima as an expatriate more than an immigrant trying to reconstruct the ex-status of her past. The novel presents the theme of dislocation and pain of building a new life in a different world. The endeavor of building a new life brings loss and pain. With its discussions and interrogation of the diasporic ideas of identity, dislocation, alienation and displacement the novel becomes a typical novel of Indian diaspora.

References

1. Anand, Silky Khullar. Ed. *Women Writers of Indian Diaspora*. New Delhi: Creative, 2005, Print.
2. Ashcroft, Bill et al. *Key Concepts in Postcolonial Studies*. London: Routledge, 1998. Print.
3. Lahiri, Jhumpa. *The Namesake*. New Delhi: Harper Collins, 2004. Print.
4. ———— *Interpreter of Maladies*. New Delhi: Harper Collins, 1999. Print.
5. Telugu, Sireesha. "Misnaming and Renaming: The Power of Names of Makers of Identity".
6. Murali Manohar. Ed. *Contemporary Indian Women Novelists in English*. New Delhi: Series, 2010. Print.
7. Nityanandam, Indira. *Jhumpa Lahiri: The Tale of the Diaspora*. New Delhi: Creative, 2005.
8. Print.

**The Veiled Anguish: Troubled Female Psyche in
Yasmina Khadra's
*The Swallows of Kabul and The Attack***

Abstract

The very word Psyche defines Merriam Webster as “the soul, mind or personality of a person or group” and exposed to varied interpretations and readings when linked to female. The condition of women in general as delineated in art, literature and theory as subjugated, oppressed, marginalized, isolated, exploited, enslaved and chained. Literary analysis as well as, theoretical expositions displays female existences as Other. Then, how tragic is a Muslim woman subjected to amidst violent conflicts? Yasmina Kadra, the pseudonym of Algerian born French writer Mohammed Moulessehoul, sketches the troubled lives of Muslim women in his fiction *The Swallows of Kabul* and *The Attack*. The study unveils the suffocating experiences of veiled women in the light of socio political aspect prevalent in Afghanistan as well as in Israel/ Palestine conflict.

Introduction

Women in general and those in Afghanistan in particular have been going through gender equity in its severe form since ages. Forceful marriages, lack of freedom, lack of identity, limited space in terms of mental, social, cultural and psychological level are perpetrated towards the Afghan women. Socio-cultural extremism and religious elements continue to pose serious obstacle towards the development of women in Afghanistan. *The Swallows of Kabul* traces the traumatic condition of two Afghan women under the oppressive Taliban rule. It paints the enduring lives of Mussarat, an ailing wife of the Taliban Prison Guard Atiq, and an extremely beautiful Zunaira who quests for freedom.

Khadra candidly elaborates the ill effects of Taliban's tyrannical rule. People are all confined to the life of desolation. Seeking pleasure is considered as a deadly sin. Women have to be in *burqas* and should keep aloof from the public. They are treated in the society as absolutely worthless like objects, possessions, not like human beings. The city of Kabul is presented as chaotic; it is suffocating. “It is as though a window to hell has partially opened in the sky.” Mussarat is a very traditionalistic domestic woman, terminally ill and who

Shamlal A. Latheef
Assistant Professor
Department of English
M.E.S. College, Nedumkandam
Idukki.
e-mail: shamlateef@gmail.com

is always subservient to her husband. On the contrary Zunaira, a former lawyer is self witted. She revolted against the practice of *burqa*. She tries to be alienated from her husband and wishes to be independent.

Women are treated in a subordinate position under Taliban *sharia* law: a woman has to cover in *burqa* when outside; she is not allowed to leave her house unless she is accompanied by a male relative; she is denied education; she is forbidden from working; she is not allowed to choose where she will live or who she will marry; she is curtailed from using cosmetics and jewelry; will stone to death if finds guilty of adultery. *The Swallows of Kabul* illuminates the harsh realities of the despotic Talibanism that implements *sharia* on the innocent subjects.

The novel opens on a despicable, mean act of stoning a woman charged of prostitution. Nobody is enquiring about her part in the allegation. Men are quick to pick up the stones and fire. Zunaira couldn't believe her ears on hearing that her husband had stoned a woman: "You stoned a woman? . . . Mohsen, come on, you couldn't have done such a thing. That's not your way – you're an educated man." (37) Hirsi Ali, Dutch-American activist and author, in her work *The Caged Virgin: An Emancipation for Women and Islam* perceives women in Islam as ". . . the property of their fathers, brothers, uncles, grandfathers, or guardians." Not so distinct is the case of the Christian Holy scriptures. In the Ten Commandments, for instance, women are clearly viewed as property: "Thou shalt not covet thy neighbor's house, thou shalt not covet thy neighbor's wife, nor his manservant, nor his maidservant, nor his ox, nor his ass, nor any thing that is thy neighbor's."

Mussarat characterizes a kind, loving, family wife devoted to her husband, Atiq. She is abstained from all the atrocities that whirled around. Though she is ailing she wants to perform her wifely duties until the end. Mussarat's mental state is worsened on her ill health and is really terrified of her losing beauty. She did everything to "make herself beautiful, to put mascara on her lashes and upon her eyes so wide that nothing in Atiq's eyes could escape her notice" . . . but she "is decomposing faster than her prayers" (120). Atiq, in this context, has been advised to divorce her that signifies the meaninglessness of women's life. Her final act of volunteering herself to be in the place of Zunaira for execution reflects that her death is more a gift to Atiq than she is living dead.

Zunaira, a self respectful woman of high status couldn't tolerate the stringent, barbaric laws that the Taliban administered. She refuses to wear *burqa* and prefers to stay inside her four walls. "Here at home, at least, when I see my reflection in the mirror, I don't have to hide my face." (76) However, she accepts *burqa* as a protest against the subjugation of women. "It's become her fortress and her refuge, her banner and her renunciation." She put on it as "her shroud of misfortune, which she doesn't even take off to go to bed." (125) On a frenzied state she indulges in a fight with her husband, Mohsen and catapults him towards the wall. No other way is as effective as memories of the past in establishing the troubled psyche. And it brings vigour when Zunaira "sought refuge in memories of long ago, of the days when children sang in public squares now besmirched by dirt and disfigured by gallows." (72)

Contrary to Zunaira and Mussarat, Sihem Jafferri of Yasmina Khadra's *The Attack*, blows herself up in a crowded restaurant, most of whom are children, caused her husband Dr Amin under suspicion.. Sihem is a non practicing Palestinian Muslim living in Israel with her surgeon-husband, Amin. She sacrificed her life for the cause of nation-state. Her willingness of action literally subverts the women stereotypes----- submission and victimization. Sihem's intentional and deliberate move towards the cause renders a much debated feminist colouring. As Amin searches for answers on Sihem's choice, he is told: "Sihem was a woman, not just your woman. She died for others. . . . the fact of being woman doesn't disqualify or exempt a resistance fighter. Men invented war; women invented resistance. Sihem was the daughter of a people noted for resistance." (226-227). She justifies herself

in the letter sent to Dr Amin from Bethlehem:

What use is happiness when it's not shared,
Amin, my love? My joys faded away every time
yours didn't follow. You wanted children. I
wanted to deserve them. No child is completely
safe if it has no country. Don't hate me. (69)

She left open a very crucial question: what could have been drawn Sihem, an Arab totally integrated into Israeli society, into a path of Islamic extremism.

The 'Swallows' of Kabul symbolizes those women in *burqas* curtailed of freedom and are described as powerless and insignificant, as they are the scum of the society. Whereas, Sihem Jafferi rose in revolt against the establishment; she attacked the customary prejudices to seek freedom in true sense. As John Stuart Mill in *The Subjection of Women* opined freedom that "after the primary necessities of food and raiment, freedom is the first and strongest want of human nature."

Works cited

- Ali, Hirsi. *The Caged Virgin: An Emancipation for Women and Islam*. New York: Free Press, 2014. Print.
- Khadra, Yasmina. *The swallows of Kabul*. Trans. John Cullen. London: Vintage, 2005. Print.
- . *The Attack*. Trans. John Cullen. London: Vintage, 2007. Print.
- Mill, Stuart. *The Subjection of Women*. London: Longman, 1869. Print.
- "Psyche." *Merriam-Webster.com*. Merriam-Webster, 2011. 8 May 2011. Web.

Broken verses: The Plight of Muslim woman stopped being an individual and started being an Entire Religion

Abstract

Islam and Muslims have never been as heavily demonized or marginalized in Western discourses as in the post 9/11 era. When they are being also represented as the sources of fear and threat. A significant focus of western discourse on Muslims has been on Muslim women. Muslim women, especially veiled Muslim women, have always captured the imagination of people in the West, and these women's relationship with Islam has been the subject of much speculation in western mainstream and academic circles. As many scholars agree, Muslim women in contemporary western discourses have often been depicted as either victims or escapees of Islam or, more recently, as the pawns of militant Islam. The popular genre of Muslim life narratives, which have proliferated in the years after the events of 9/11 too, have also reiterated the account of Islam as a backward and misogynist religion and Muslim women as powerless victims of Islam.

Women play a unique role in societies that define themselves in primarily religious terms. In religious fundamentalist contexts, women are central to the projection of a community's moral image. The pious community's women should look and behave in ways that underscore the collective piety. As embodiments of the purity and authenticity of the culture, they become the men's first targets because they are border markers and compelled to carry their culture's values. This paper focuses on a selection of such novels, and argues that, due to their intense involvement with the Islamic sacred and spiritual, they create metaphoric sacred spaces almost unprecedented in English literature. In this paper, in order to explore the notion of the Muslim women, sacred and its representation in contemporary English literature, I will look briefly at three novels, *The girl in the tangerine scarf* (2006) by Mohja Kahf, *Minaret* (2005) by Leila Aboulela, and *My Name is Salma* by Fadia Faqir.

Muslim women tired of misinterpretations, wanted to express their reality without having to side along one or other camp, secularists or fundamentalists. They inaugurated Muslim feminist characters, a concept which in earlier times, was thought to be an oxymoron. In a postcolonial critical frame work this paper try to scrutinize the approaches that deal with religious identity by giving voice to hitherto silenced group of people, Muslim women. In the last decade, within

Farisha V.M.
MES College, Nedumkandam
Idukki Dist.

such a context of representation of Islam and Muslim women in the West, a number of novels, written in English by women authors and published in western countries, tell a different story about Islam and about Muslim women. These novels foreground the spiritual dimension of Islam and insist on a deeply devotional relationship between the main female characters and the religion of Islam. All these texts are by women writers and explore the lives of women Muslim characters. The novels were selected partly because they are among the most critically acclaimed works published in the last decade in the West. Gayatri Spivak's contribution is indeed of considerable worth in this connection since the concept of subaltern (and in this case female subaltern) provides a sustaining backdrop for theorizing the subordination of women. Besides taking sub alternate as an intricate postulate of the contemporary postcolonial paradigm, it also stands as an umbrella concept exposing certain marginalized subject positions breathing in any specific social or cultural context. The dual colonization women are subject to during and even after colonization have been addressed by Spivak remarkably. Heresay *Can the Subaltern Speak?* acts as an onslaught on the most agreed-over meaning of the term 'Subaltern'. She has rather extended the scope of sub-alternate to all those (with a suggested caution) who are out of the ruling hegemony of imperialism. However, at the end, she specifically alludes to the female subaltern, who is actually faced with double colonization. Postcolonial or Third World feminism stands apart from the White feminism of the West while denouncing it in the favor of non-White or non-Western woman. To the West, Islam is all unchanging and monolithic opening up ways for the slavery and subordination of women. Such ideas actually belong to the camp of Orientalist thoughts upheld by the West where, as Said documents, there has been a growing fascination with *harem* and veil which mutually signify women's oppression and eroticism together. With special reference to Islam, we have Muslim feminist writers who, through their theory, have been striving to resolve the intricacies involved in the issue. Leila Ahmed is one of these who are intensely conscious of the egalitarian spirit of Islam. Ahmed's *Women and Gender in Islam* (1992) dilates upon her quest of the historical roots of a debate which is contemporary.

Miriam Cooke in *Women Claim Islam* (2001) evaluates the effect it casts on the lives of Arab women when especially reflected through the literature they produce. Arab women, today, are striving to be heard and seen primarily on account of the Islamic discourse which is widespread and gives unprecedented importance to women. The discourse entails the revolution in information technology as a result of which there is a strong sense of networking and linkage among women and at all national, transnational and international levels. They are today questioning the male hegemony in terms of production and establishment of official Islamic knowledge. Muslim feminists, either secular or Islamist, are directing their energy in interrogating how contemporary advancements in technology besides the renewed meta-cultural consciousness of 'Islamic' can go parallel when it comes to the issue of survival in a world which is rapidly transforming. Cooke casts a glance at the narratives of the Arab women who crave to be heard with a more pronounced and redefined identity in a manner which is increasingly political. This gives birth to an Islamic feminism which is sort of burgeoning. Islamic feminism, with Cooke, is no less than a paradigm proper since she provides historical, theological and political foundations for its establishment. Cooke's argument is based on the trajectory of political and historical developments in the Arab world.

The Girl in the Tangerine Scarf was published in 2006, and it tells the story of Khadra Shamy, a Muslim Syrian immigrant in the United States. The story is told by an omniscient narrator who uses flashbacks and flash forwards. Several of the events in the story take place in Indianapolis, where Khadra "spent most of her growing-up years" (KAHF, 2006: 1). Her father had decided to move there in order to work at the Dawah Center, a Muslim community center, where he believed he would answer God's call and help other Muslims. Before that, the first place Khadra lived in the United States was Square One, in the Rocky Mountains. Despite living among American kids, she did

not face any kind of discrimination: “The American kids in Square One didn’t seem to know yet that they were supposed to be better than the rest because it was their country. Their parents were all students at the same university”(KAHF, 2006: 10). Nevertheless, the sense of not belonging was soon to come to her as they moved to Indiana. In their first day, when they were still unpacking their belongings, some boys threw glass bottles at their doorstep, and the Shamy family realized they were not welcome. At school, things were not different. She felt that she not only had to face the prejudice on the part of other students, but she also had to live with the indifference of the teachers. In one incident at her school when two boys harassed her and ended up tearing her scarf and leaving her bareheaded, a teacher does not sympathize with her: “Mr. Eggleston came out of his room down the hall. Silhouetted by the daylight streaming from the the double doors at the end of the hallway, he shook his head, gave her a look of mild disapproval, and went back inside” (KAHF, 2006: 125). At home she faced the religious restrictions like you cannot do this and that as a Muslim Women. The two diversely breaking identities broke her. As a married woman Khadra goes through the most dramatic period of her life. Although she seems happy in the beginning, the couple soon starts to have problems as Juma imposes more and more limits on her. He first tells her to stop riding her bicycle, which he considers inappropriate for a Muslim woman. Khadra in her immature form passively accepts all the teachings her family and community passed onto her as the only existing truth. Her pupal transformations are the several phases she goes through in her life when her beliefs clash with every day life and the cultural environment of the place she lives. Finally, the older Khadra behaves as a mature sexual adult who respects herself and her condition as a diasporic woman.

Mohja Kahf’s representation of an Arab immigrant woman in *The Girl in the Tangerine Scarf* demonstrates how the space of diaspora is central to the reconstruction of a woman’s subjectivity, informed no longer exclusively by rigid social codes from the Middle East. Despite being criticized, the mature Khadra, now conscious of her hybridity, wears a tangerine scarf and blue jeans, combining signs of the American and the Arab cultures according to her personal assessment and choices.

My Name is Salma is a novel of a search for and an assertion of identity. The name ‘Salma’ is an Arabic word which means ‘safe and sound’. Ironically Salma, the protagonist, is far from being safe or secure. This is a touching tragic story of a young Bedouin girl of seventeen who commits adultery and is pregnant out of wedlock. She is helped to escape by her teacher, Miss Naila, to flee away from her home village in order to preserve her life. Salma, who has violated the honour code of her tribe, has to be killed by a near male kin to restore the family honour. Her brother Mahmoud will be a living ghost that will haunt her to shoot her between the eyes till the end of her life. This young Arab Bedouin Muslim girl undergoes a detrimental journey from the East to the West, from the Arabian village of Hima in Jordan to the western English city of Exeter. The story is one of a physical and psychological journey from innocence to experience, from an Arab set up and Arabic language to an English environment and English language and culture, and from life to death. In her own natural ‘habitat’, Salma is an outcast, and in her new adopted ‘home’ - England, she would always feel that she is an unwelcome outsider who does not belong. She is an ‘outsider’ and a ‘foreigner’ wherever she goes. When Salma meets an English man who asks her about herself, she says “If I told him that I was a Muslim Bedouin Arab woman from the desert on the run he would spit out his tea. I am originally Spanish, Salma would lie.” (p. 27). And in another context she says:” Had I told him I was Arab he probably would have run faster. A Bedouin from a village called Hima, whose blood was spilled by her tribe for any vagabond to drink it...I changed my name, address, past and even changed countries to erase my footsteps.”(p. 217). Many were the important things that the protagonist had to drop out in her new environment: her mother, father, brother, and most importantly, her baby. She had also to drop her white ‘veil’, as a symbol of her own religious identity in order to be able to survive in a western European set up. This has further accentuated her feeling of guilt:”...white veil, I slid it off,

folded it and placed it on the bed. ...It felt as if my head was covered with raw sores and I had taken off the bandages. I felt dirty as a whore...a sinner who would never see paradise and drink from its rivers of milk and honey.”(p. 114).’ Rivers of milk and honey ‘is a quote and a concept of reward taken from the holy Quran. It is part of a Muslim sensibility with which the novel abounds. A Muslim sensibility is quite evident in the narrative in the form of quoted Quran verses or Muslim religious concepts and practices such as prayers, wearing of a veil for women, forbidding the drinking of alcoholic drinks and the practice of premarital sex. Salma will always think of herself as a sinner, and would feel like being put into a washing machine to wash herself clean out of her sins. This caricaturization of her need of purification is more exaggerated in a death wish of being torn to pieces by a dog as a final salvation for herself from sins and sufferings. Traditions and religion play a significant propelling agent in the events of the novel. What has come to be known as the ‘crime of honour’ was the engulfing issue in the story of Salma. Salma, who escaped safely to England, is constantly haunted by the imaginary revengeful figure of her brother. She is also haunted by her own guilty conscience. Therefore, she goes to a surgeon and asks for an amputation of her nipples which stand symbolically for the sexual act, the sin she has committed in adultery; the nipples also stand for the nursing of one’s baby, again a deed she would always feel sorry and guilty for not doing it.

Leila Aboulela’s fiction might be said to represent a turning point in relation to the depiction of Islam and Muslims in contemporary British fiction. Aboulela’s writing challenges the stereotypical images made by Rushdie, Kureishi and Ali. In a sense, she is “writing back” in order to give voice to those Muslims who for some time were depicted negatively in British fiction. Strikingly, Aboulela herself, as an educated female writer who wears the hijab, is a practical riposte to the image of the oppressed woman in Islam. Unlike those previous writers who attempt “to ‘explain’ or satirise Islam from a western perspective”, she tries to “write from inside the experience of growing up and living with a network of customs and beliefs” (Philips, 2005). Writing from the inside, Aboulela has created a new image of Islam and Muslims; once the perspective is changed, the positions of the Self and Other do the same. In the first phase, Islam was the Other, but now, in the new phase, it is the Self. Writing about Islam and Muslims, for Aboulela, is writing about herself. The image of Islam is hers and in defending Islam she is defending her own beliefs. Aboulela has written three novels and the collection of short stories, *Coloured Lights*. Her three novels, *The Translator*, *Minaret* and *Lyrics Alley*, attempt to negotiate the controversial issues between Islam and the West in the present world. *Minaret* is the story of a Sudanese girl living a happy and comfortable life in Sudan. Her family is rich and aristocratic. Her father is a close friend of the president and her mother is from an important family. Brought up and educated as western, Najwa enjoys travelling to Europe, attending parties in the American Club in Khartoum, and having fun generally. Then a coup in Sudan suddenly changes her life. She becomes a refugee in London, her father is executed, her mother dies, and her twin brother is put behind bars for drug dealing and fighting with a policeman. In London she is free enough to have an affair with Anwar who was her friend in Khartoum University and who fled to London after another coup. After leaving Anwar and to assuage feelings of guilt and find relief, Najwa turns to Islam; she wears the hijab and becomes religious. In London, without a family to help her, she works as a maid in a Muslim house where she falls in love once again, with Tamer, the younger brother of her employer. In spite of their different ages and positions, Najwa and Tamer’s similar religiousness led Tamer to insist on marrying her, but his family refuses. In spite of America’s bad reputation in the eyes of many Muslims, Tamer has his own image. He says: “here [in London] there’re all these anti-American feelings. It bugs me. My American teachers were really nice’ automatically to the conflict between the colonisers and the once-colonised; it can be extended to conflict between those within the same culture, where one adopts a colonial perspective toward those who challenge them. Further, the novel portrays Islam as a global religion which attracts people from different nationalities and

classes. It diversifies Muslims. Najwa is from Sudan, Islam in *Minaret* is a source of inspiration for the poor and the rich, the simple and the important people.

Moreover, the novel mentions some important and famous Muslim personalities, Islamic movements and countries without highlighting the differences between them; this is arguably done to focus on their belonging to one religion rather than differences between them. The personalities are Khomeini and Amr Khalid, the Islamic movements are the Muslim Brotherhood and Hizbullah, and the countries are Sudan, Iran, Iraq, Britain. In opposition to the negative image of the hijab in the West, in *Minaret* it is represented positively. Not merely a traditional headscarf, it is as Islamic as praying and fasting. Throughout the novel, there is a link between wearing the hijab and being religious, but on the other hand, there is no relationship between the hijab and being before wearing the hijab, Najwa was young, rich and a university student. In London after wearing the hijab, she is older and poorer and works as a maid. This contrast in social positions could be misunderstood and the hijab might be held as the cause. Muslims are usually depicted as members of a group, a community or a society. This membership comes at the expense of their individuality. Najwa challenges this assumption about the relationship between Islam and individualism. The decision that she has taken to be religious is hers alone and was made without any kind of pressure from family or society. She accepts Islam as a way of life and a form of identity. Religiosity, she thinks, will benefit her. When she went to the mosque for the first time she reviewed her feelings: "I wanted to be good" (Aboulela, 2005a, p. 237). Before she had thought of others: the Sudanese who lived in Khartoum; the university students; and herself as one of a group of friends gathering in the American Club, as one of her own family in Sudan and then in London, as the sister of Omar, and finally the lover of Anwar. Now she thinks for herself for the first time in her life. In this intensified state of individuality she chooses to be religious. In *Minaret* therefore we see an attempt to represent the hidden side of the picture of Islam by its focus on Islam's capacity to effect self-realisation and spiritual consciousness in an individual. Najwa's loneliness in London symbolises, arguably, her loneliness in the materialistic world. She "yearned to go back to being safe with God" (p. 242). God is her source of safety. Her sense of being close to God helps enhance her spiritual nature with its different shapes. "I felt a kind of peace" (p. 237) and "now I wanted a wash, a purge, a restoration of innocence" (p. 242). She seeks for "exfoliation, clarifying, deep-pore cleanse" (p. 247). The demands she places upon her spiritual life are the consequence of growing weary of her previous spiritually empty existence. "I'm tired of having a troubled conscious. I'm bored with feeling guilty" (p. 244). At this stage, she has discovered a new kind of pleasure. "I reached out for spiritual pleasure and realized that this was what I had envied in the students who lined up to pray on the grass of Khartoum University" (p. 243). The discovery of spiritual fulfillment is very striking here as it led to the discovery of the self. Many times before, Najwa envied those students who prayed and wore hijab at university. She even envied her servants who woke up early in the morning just to pray the dawn prayer. Her materialistic life did not provide an answer to her questioning self. She awakens to the realization that materialistic side of human life is limited and spirituality is not just a mere pleasure but a means of knowledge, too. In short, Najwa's religious spirituality is her source of safety, peace, purging and soul. The importance of Aboulela's writing in this context is that it challenges the western image in general and these colonial images in particular. I would also argue that in itself the strong affiliation to Islam demonstrated by Aboulela is a postcolonial act. She "writes back" to the western centre making visible those marginalised Muslims who are frequently subjected to polemical prejudice. In addition to challenging the colonial image and giving voice to marginalised Muslims, she is an Islamic postcolonial writer because she "posit[s] complex personal relationships experienced by women whose identities are co-defined by Islam and the post-colonial condition" (Stotesbury, 2004, p. 69). Aboulela, in a sense, "shifts" the centre without undermining the margin. In fact, in spite of her belief in the centrality of Islam, she does not seem to

believe in the marginality of the West. She writes against stereotyping Islam as well as performing a similar function with the West by writing sympathetically about conservative Muslims in the West, Aboulela resists the colonial perspective at its centre.

The West, historically, is the geographical and cultural centre of the polemical discourse directed against Islam and Muslims through Orientalism and colonialism. If the colonial discourse of the West is replete with Islamophobia and racism against Muslims, Aboulela's fiction resists that through focusing on humanity equality and the right for Muslims to narrate their own values and experiences. This narration is of course in itself a function of postcolonial writing. In Aboulela's fiction, Islam is not a backward religion, Muslims are not all fundamentalists, Muslim women are not uniformly oppressed, though there are *some* fundamentalists and *some* oppressed women. The portrayal of the hijab in *Minaret* is a clear example of Aboulela's method of challenging colonial assumptions regarding the position of women in Islam. A signally important subject in colonial discourse, the hijab, as I have suggested, has succeeded in convincing many people in the West of the inferiority of Islam. "For many Westerners, the veil is a symbol of patriarchal Islamic societies in which women are assumed to be oppressed, subordinated, and made invisible" (Young, 2003, p. 80). In dealing with these assumptions, Aboulela – by according the hijab its religious significance and context – appears to differentiate herself from those Muslim female voices that tend to think of the hijab traditionally, and as a sign of patriarchy. Miriam Cooke, for example, in her book *Women Claim Islam* writes: "the veil symbolizes belonging to a religious community that is both patriarchal and powerful, but beyond it has many meanings. While some of these meanings are negatives, others are empowering" (Cooke, 2001, p. 132). The first implication here is that the woman in Muslim communities is forced to wear the hijab by "patriarchal and powerful" currents. The second is that the hijab, especially because some of its "meanings are negatives", does not seem to belong to Islam. In short, Cooke believes that the symbolism of the hijab "is so saturated with patriarchal meaning that it is difficult to appropriate for feminist purposes" (p. 136). *Minaret* challenges this point of view. Najwa's freely arrived at adoption of the hijab in London directly after leaving Anwar contradicts the influence of the patriarchal and powerful community, reverses Cooke's view, and is thus an implicit criticism of it. *Minaret* challenges the uniqueness of globalised western culture by presenting Islam as a globalised religion. Muslim characters in the novel are from different countries. Moreover, the stable life pursued by Muslims in London portrays Islam as a religion which could be followed in the heart of the western culture. Post colonial approaches also operate in *Minaret* in the manner in which the novel provides the voice of a Muslim self to challenge the voice of the Muslim other which is created from non-Muslim perspectives. The Muslims in *Minaret* are imaged by a Muslim.

Aboulela articulates her own Muslim identity and experience through her characters. By doing so, she is one of those writers who, in Mike Philips' words, "write from inside the experience" (Philips, 2005). This "from inside" writing resists the writing from outside. Said notices that "since an Arab poet or novelist – and there are many – writes of his experiences, of his values, of his humanity (however strange that may be), he effectively disrupts the various patterns (images, clichés, abstractions) by which the Orient is represented" (Said, 1995, p. 291). Writing about the self "disrupts" the colonial image of the other, and because of that, writing about the self becomes postcolonial. Aboulela clearly states her positioning of self in her writing about Islam. "I can never truly see [Islam] through western eyes. I am in this religion. It is in me" (Aboulela, 2007a). The positive portrayal of Najwa's strong religiousness and affiliation to Islam could be linked with Aboulela's discovery of the importance of religiousness in her real life. Whenever Najwa justifies wearing the hijab or her spiritual fulfillment, Aboulela herself could be imagined justifying her own decisions. Since culture is the field of the battle, *Minaret* resists the assumed inferiority of Islam and the assumed superiority of the West. *Minaret*, arguably, is an indirect critique of the indirect colonial discourse embodied in current western

culture.

Islamic Postcolonialism encourages Muslims to read and analyse the fiction written about them and their religion through adopting postcolonial theories as their perspective. Such involvement of Muslims in postcolonial analysis should lead to more realistic and authentic readings and analysis of the portrayal of Islam and Muslims in fiction. Islamic postcolonialism, in short, provides Muslims with the space they need to speak out. By resisting colonial discourse, critics and writers who adopt the perspectives of Islamic postcolonialism will be able to extend the spaces to which postcolonialism can reach and shed light on a neglected area. Orientalism and colonialism are the roots of the distorted image of Islam and once colonized countries in general. Within this context, Islamic postcolonialism might be considered a bridge that connects the Islamic world, as a formerly colonised space, and postcolonialism, a theory aimed at defending all colonised countries and cultures.

Conclusion

The cross-cultural and multi-ethnic feminist currents among the post-colonial societies have recently developed feminist postcolonial theology as a subject of both academic and sociological scrutiny. This reveals that women are no longer the silent followers and observers of religion but are now in a position to code and even re-code it in their favor. The post 9/11 situation has changed the global order into something most heterogeneous and disparate where things seem to be in strict compartmentalization labeled as 'ours' or 'theirs'. This call for an increased consciousness on the part of feminists belonging to third world and post-colonial backgrounds, especially when there is either an existence or anticipation of the neo-colonial order they are likely to be a part of.

References

1. Aboulela, L 2005, *Minaret*, Black Cat, New York.
2. Bhabha, H. (1994) *The Location of Culture* (London: Routledge).
3. Cooke, M. (2002) Multiple critique, in: Donaldson, L.E. & Pui-Lan, K. (Eds), *Postcolonialism, Feminism and Religious Discourse*, pp. 142–161 (London: Routledge).
4. Faqir, F. (2007) *My Name is Salma*, Black Swan.
5. Kahf, Mohja. *The Girl in the Tangerine Scarf*. 1st ed, New York, NY: Carrol & Graff Publishers, 2006.
6. Kahf, M 1999, *Western representations of a Muslim woman*, University of Texas Press, Austin.
7. Mernissi, F 1991, *Women and Islam: An Historical and Theological Enquiry*,
8. Translated from French by Mary Jo Lakeland, Basil Blackwell ,Oxford.
9. Mishra, S 2008, 'Islam and democracy: comparing post 9/11 representations in the
10. U.S prestigious press in the Turkish, Iraqi and Iranian contexts', *Journal of Communication Inquiry*, v.32, n.2 April, pp.175-178.

When the Game becomes Serious – Language and its Plays

Abstract

This paper touches on the broad theme of language and identity. More specifically, the paper attempts to look at how language helps establish cultural otherness/strangeness and how this discourse later adopts oppressive measures in order to make sure that the “strangers” remain strangers. Two poems “Language Games” by Agha Shahid Ali and “The Old Language” by Ronald Stuart Thomas are used to point out how language revolves around the play of words and how these games contribute in forming wider systems of knowledge.

Ludwig Wittgenstein says in his *Tractatus Logico-Philosophicus*– ‘what can be said at all can be said clearly, and what we cannot talk about we must pass over in silence.’ Concepts need not be clearly defined in order to be meaningful. That is words or language do not always mean and signs do not always signify but there are other ways of understanding things. Silences and metaphors, limits and games speak to us. There are conflicts and fissures but then it is not necessary that we have to understand each and everything always. Language game is a philosophical concept introduced by Wittgenstein. According to him the rules of language are analogous to the rules of games. Using words to make a sentence in a language is like making a move in a game. Both are governed by an underlying rule. This analogy between the language and the game brings forth the idea that the meanings of words are never fixed or stable, but always depend upon the context. Language game refers to simple examples of language use and actions into which the language is woven. It is used to refer to forms of language simpler than the entirety of a language itself. “Language Games” is a poem written by Agha Shahid Ali. He was a Kashmiri-born poet who lived in America due to a self-imposed exile. His poetry consists of themes of nostalgia and otherness. His love for his motherland and the pain of separation exude through every line of his poetry. It might have been the difference between his own ideal conceptualization and the realities of the war and trauma of Kashmir that caused the exile. The poem “Language Games” itself is a language game since the poet tries to convey the larger issues of exile, longing, cultural otherness, poetry and language by using the simple language that he uses in order to write about the games. It is not the meanings of the words that are important in the poem but the meaning of the signs. One’s ability as a reader depends

Anupa Rose Babu

Assistant Professor in contract,
Deva Matha College, Kuravilangad,
Kottayam Dist. Kerala
email: arb2sirius@gmail.com

on one's receptivity of the signs. The meanings generated from the signs depend upon the linguistic, cultural and ideological constitution of the reader. Some of the signs that AghaShahid Ali uses in the poem include: the title "language games" which stands for its philosophical meaning as well as the literal meaning, the word "seven" which is repeated three times in the poem, the noun "asylum" etc. Language is like a double faced coin; on one side is the face of the monster that unleashes oppression and on the other side, the face of the victim empowering oneself. The voice in the poem is that of a Kashmiri – American poet, an adult who has undergone a great deal of sorrow and experiences and at the same time a baby trying to stand on its own feet. The adult is the man who left his home because it ceased to be his home. This might be because of the violence over the border and the militant insurgency in Kashmir. The baby is the poet who is attempting to settle in this foreign country by trying to fit into its norms and like any baby he begins his journey towards experience by playing games. However the games mentioned in the poem has a cruel quality attached to them. The poet has to go 'purposely mad', in order to attain asylum. Asylum here refers to a shelter from danger or hardship but by the time we reach the end of the poem the asylum is used to mean a hospital for mentally incompetent or unbalanced person. The poem seems to end in a pleading and yet a revengeful note asking the person who made him act like mad, to go mad. The existential anxiety that the poet faces since he is neither there nor here is very evident. The "you" clearly has an upper hand and 'your house' can mean the foreign country. In that sense the poem can be about poetry and writing. The 'therapy of syllables' can mean his desire to write, to quench the flame of his longing for his mother country but their prescriptions made him fail. A mad person is someone who is blissfully unaware of himself and others, the poet might have had this freedom and nonchalance in his mind when he pretended to be mad. But the later lines tell us that he failed before their power. Finally he accepts his defeat when he says that 'no chance of you insane'. He wanted the dominant side to lose itself in pain and suffering, for that is what madness is, to assume authority over it and patronize it under the guise of curing it. This lyrical poem talks about games like crosswords, anagrams, Scrabble game, Truth AND (not or) Consequences and Charades. The first letters of all these games except the first two are capitalized. The speaker and the addressee are trying to play, to have fun using language. However fun is solely derived by the addressee since he or she seems to be winning all the time and the poet keeps losing. The poet has not yet acquired mastery over the language in a way his dominant other has. 'Words never evade you, /you can build anything.' The poet is reduced to playing/ performing charades since he has not acquired mastery over the language of the oppressor. His voice is not heard and he is only seen by the people around him and it is possible that they are not seeing his actions, but the color of his skin. The poet is not free in language and free with language as of now while the addressee is playing with language as well as playing with him. Both madness and play have one thing in common; both do not require conscious effort. We lose ourselves in both madness and play and both refer to a state of the mind in which all inhibitions are lost and all knowledge about what is good and bad is absent. In that sense they refer to a completely "id-ridden" state in which both ego and super ego are totally absent; a purely instinctual state driven by the motives of pleasure. The other player is in this state, completely enjoying himself (his constant urge to play more games makes this evident) regardless of the pain and disappointment of the poet.

**You can build a whole hour
with only seven seconds.**
Framed with consonants,
we resumed play, no vowels
in my seven letters.
I saw you do wonders without vowels.
Let's give up, I said,
but you cried: Truth AND Consequences!

Language is intricately tied up with identity and self. In one sense it is the language which constitutes the self and identity. This language game is in no way beneficial for the poet to constitute himself, except maybe to place himself on the oppressed side. This makes him aware of his state as a person who is suspended in limbo. He is the cultural other/ the stranger in his own native land which is Kashmir and also in this foreign country. The strangeness he faces is both from within and from outside.

The poets Ali and Thomas write about the oppressive tendencies of the language standing rooted within the oppressor's language. Despite the fact that the speaker of "Language Games" presents himself as a man who has not attained the "way" with language, we see the display of clever and subtle use of irony and lyrical power in the poem. Ronald Stuart Thomas was a Welsh poet and a priest who was against the Anglicisation of Wales by the English. We can witness the same streak of oppression faced by Ireland here. Thomas addresses England and asks her the question why is it that she has made the very language he inherited from his ancestors a strange tongue which makes them dance to the tunes and the whims of the oppressor. It should be remembered that Thomas was a man who had excellent command over English language which made him a Nobel Prize nominee. It seems interesting that both the poets were intimately connected to the English language than they were ever connected to their own languages; Ali not so much but Thomas hardly ever wrote in Welsh. Thus, both poets seem to be involved in a constant process of deconstruction and reconstruction, a constant flux in which the meaning is postponed. Do these poems transcend time? And if they do, it's not the words printed on the page that causes it, but the meanings the readers ascribe to them. They are relevant today because of the signifiers that are in constant motion to arrive at meanings and then defer them periodically.

The second poem clearly demarcates between the oppressed and the oppressor. The Welsh people are depicted as a conquered race whose language has been taken away from them and with language their identities as well. The tone is authoritative ('answer me now') and this sets off the idea that the poet has become the master of this language. Thomas is the poet who saw English language as promoting materialism and greed. There is a clear invocation to return to the call of nature, rejecting the technology and machines, in the poem. The 'brisk pattern' of nature needs to be renewed. The children's song that he mentions in the poem directly relates to the sense of the aboriginal Welsh community. The tendency to mechanise has destroyed their sense of togetherness and thus the shared experiences have vanished. The stories have died out and in this process language itself seems to have conspired against language. But the poet is hopeful of the arrival of spring. The innocence of children can rejuvenate the stories. The new songs relate to the idea of 'play' described earlier. Children twinned by joy and innocence sing when they are happy and this state is playful and joyous. They lose themselves in their songs and their innocence might be balm for our sorrows.

Both the poems read to each other with the message that the woe is a shared one. We are not alone in suffering. Other people have suffered before us and they too have faced questions of existential anxiety and cultural displacement. There are ways to subvert the oppressive forces and the tool that Ali and Thomas use is the same- language in contestation of language.

Bibliography

1. Derrida, Jacques, and Alan Bass. "Structure, Sign, and Play in the Discourse of the Human Sciences." *Writing and Difference*. London: Routledge, 1978. 351-370. Print.
2. Eagleton, Terry. *Literary Theory an Introduction*. 2nd ed. Hoboken: John Wiley & Sons, 2011. Print.
3. Wittgenstein, Ludwig, and Bertrand Russell. *Tractatus Logico-philosophicus*. London: Routledge, 1992. Print.

**സോഷ്യലിസ്റ്റ് സ്ത്രീസങ്കല്പം മുത്തശ്ശിയിൽ
- ഒരു അവലോകനം**

സംഗ്രഹം

ചെറുകാടിന്റെ മുത്തശ്ശി എന്ന നോവലിന്റെ വായനാനുഭവം ചർച്ചചെയ്യുകയും, സൂക്ഷ്മ നിരീക്ഷണത്തിലൂടെ കഥയുടെ സവിശേഷതകളെ എടുത്തുകാട്ടുകയും ചെയ്യുന്നതാണ് ലേഖനം. സോഷ്യലിസവും സ്ത്രീവാദവും ഇതര പ്രസ്ഥാനങ്ങളും മുത്തശ്ശിയിൽ കടന്നുവരുന്നവെന്ന് ബോധ്യപ്പെടുത്തുകയും, കൂടാതെ സമകാലികമാക്കപ്പെടുന്ന കഥാതന്തുവാണ് നോവലിലുള്ളത് എന്ന സൂക്ഷ്മാവബോധത്തെ വായനക്കാരിൽ എത്തിക്കുകയുമാണ് ലേഖനത്തിന്റെ ആത്യന്തിക ലക്ഷ്യം.

ആമുഖം

മലയാളസാഹിത്യചരിത്രത്തിൽ കൃത്യമായ രാഷ്ട്രീയാവബോധമുള്ള എഴുത്തുകാരിൽ ചെറുകാടിന്റെ സ്ഥാനം പ്രഥമഗണനീയമാണ്. ഇരുപതാം നൂറ്റാടിന്റെ മധ്യഘട്ടത്തിൽ കേരളത്തിൽ ഉായിരുന്ന സവിശേഷമായ രാഷ്ട്രീയ സാമൂഹിക അന്തരീക്ഷത്തിന്റെ പശ്ചാത്തലമാണ് ചെറുകാടിന്റെ നോവലുകളെ ശ്രദ്ധേയമാക്കുന്നത്. സ്വാതന്ത്ര്യസമര പോരാട്ടങ്ങൾ ഇടതുപക്ഷ ജനാധിപത്യ മുന്നണിയുടെ ആവിർഭാവം, അധ്യാപകപ്രസ്ഥാനം, തൊഴിലാളി യൂണിയൻ - എന്നിങ്ങനെ മലബാറിനെ ഇളക്കി മറിച്ച വിപ്ലവപ്രസ്ഥാനങ്ങളുടെ ആരംഭകാലത്തെ പ്രതിപാദിക്കുന്ന തായിരുന്നു ചെറുകാടിന്റെ നോവലുകൾ. 'മുത്തശ്ശി'യും കൈകാര്യം ചെയ്യുന്നത് ഇതേ വിഷയങ്ങൾ തന്നെയാണ്. ആത്യന്തികമായി പെൺ കാഴ്ചയിലൂടെ യാത്ര ചെയ്യുന്ന ഒരു ആഖ്യാനം എന്ന നിലയിൽ ഈ നോവൽ മുന്നോട്ടുവെയ്ക്കുന്ന സ്ത്രീപക്ഷ വായനയുടെ അകം പൊരുൾ അന്വേഷിക്കുകയും വിമർശന വിധേയമായി വിലയിരുത്തുകയും ചെയ്യുന്നു.

സോഷ്യലിസം എന്ന ബൃഹത്തായ ആശയലോകം മുന്നോട്ടുവെയ്ക്കുന്ന വാദഗതികളിൽ സ്ത്രീസമത്വം വേറിട്ടുനിൽക്കുന്ന ഒരു കാഴ്ചപ്പാടല്ലാത്തതിനാൽ സോഷ്യലിസ്റ്റു സ്ത്രീവാദം എന്ന പ്രയോഗത്തിന് പിന്നെ എന്തു പ്രസക്തി എന്ന ആശങ്കയ്ക്കു വകയ്ക്ക്. സോഷ്യലിസ്റ്റു സമൂഹത്തിൽ മാത്രമേ പുരുഷനു സമാനമായി സ്ത്രീയെ സങ്കല്പിക്കാൻ കഴിയൂ. സമത്വാധിഷ്ഠിത മൂല്യബോധം സമൂഹത്തിന് അന്യമായി ക്കൊരിക്കലുമില്ലാത്തതോളം കാലം സോഷ്യലിസ്റ്റു സ്ത്രീവാദം എന്ന ചിന്താഗതിക്ക് പ്രാധാന്യമുണ്ട്. സ്ത്രീയുടെ വിമോചനത്തിനായുള്ള ഭൗതികസാഹചര്യങ്ങൾ സൃഷ്ടിക്കപ്പെടുന്നതിന് സാമൂഹ്യോല്പാദനപരമായ അധ്വാനത്തിലേക്ക് സ്ത്രീ പുരുഷന്മാർ തുല്യതയോടെ നില നിൽക്കണം. ഇതിന് സംജാതമായ സാഹചര്യത്തെ ഉറപ്പിച്ചെടുക്കുക മാത്രമല്ല,

Shainymol O.V.
Research Scholar
School of Letters
M.G. University
Athirampuzha
Mail:ovshyni25@gmail.com

വിവാഹം, കുടുംബം, ലൈംഗികത, അധ്വാനം, വിനോദം തുടങ്ങിയ അതിപ്രധാനമായ ജീവിത പ്രവൃത്തികളിലെല്ലാം തന്നെ ആണും പെണ്ണും തുല്യപങ്കാളികളാണെന്നും ഇരുകൂട്ടരും പരസ്പര പുരകങ്ങളായ മനുഷ്യഘടകങ്ങളാണെന്നും സോഷ്യലിസം തിരിച്ചറിവു നൽകി.

വർഗ്ഗരഹിത സമൂഹത്തിന്റെ സൃഷ്ടിയിലൂടെ മാത്രമേ ലിംഗസമത്വം കൈവരിക്കാൻ സാധിക്കൂ എന്ന പടിഞ്ഞാറൻ ദർശനത്തിന്റെ പിൻബലത്തിൽ ഇന്ത്യയിലും സ്ത്രീവാദത്തിന്റെ മാറ്റൊലികൾ അങ്ങിങ്ങി പ്രത്യക്ഷപ്പെട്ടു തുടങ്ങി. സ്ത്രീയുടെ വിദ്യാഭ്യാസം, സ്വാതന്ത്ര്യം, സാമൂഹ്യപ്രശ്നങ്ങൾ തുടങ്ങിയ വിഷയങ്ങളിൽ ഗൗരവപൂർവ്വം ഇടപെടുന്നതിനുള്ള ശ്രമങ്ങളായി.

ഫ്രഞ്ചു വിപ്ലവത്തോടനുബന്ധിച്ചുതന്നെ ഫ്രാൻസിലെ സ്ത്രീകൾ തങ്ങളുടെ അവകാശങ്ങൾക്കുവേിയുള്ള പോരാട്ടങ്ങൾ ആരംഭിച്ചിരിക്കുന്നു. ജർമ്മനിയിൽ ഫെമിനിസ്റ്റ് പ്രസ്ഥാനത്തിന്റെ മുൻ നിരയിലായിരുന്ന ക്ലാര സെറ്റ്കിൻ (1857 - 1933) പ്രായപൂർത്തിയായ സ്ത്രീകളുടെ വോട്ടവകാശം നേടിയെടുക്കുന്നതിനായി പ്രവർത്തിച്ചു. ഇന്ത്യയിലും ആനിബസന്റ്, മാർഗരറ്റ് കസിൻസ്, സരോജിനി നായിഡു തുടങ്ങിയ യീരവനിതകൾ സ്ത്രീ സ്വാതന്ത്ര്യത്തിനുവേി പ്രവർത്തിച്ചു. 1949 - ൽ ഇന്ത്യൻ സ്ത്രീകൾക്ക് വോട്ടവകാശം ലഭിച്ചു. കാര്യങ്ങൾ ഇങ്ങനെയൊക്കെ മുന്നോട്ടു പോയെങ്കിലും സോഷ്യലിസ്റ്റു സ്ത്രീവാദങ്ങളിലൂടെയുള്ള സാമൂഹിക മുന്നേറ്റത്തിനുതകുന്ന ഇന്ത്യൻ പശ്ചാത്തലം ഇവിടെ പ്രത്യേകം അടയാളപ്പെടുത്തേതു്. സവർണ്ണ ഹൈന്ദവ മേൽക്കോയ്മയും പുരുഷാധികാര വ്യവസ്ഥിതിയും ജന്മികൂടിയാൻ ചട്ടവട്ടങ്ങളും മേലാള കീഴാള വഴക്കങ്ങളും നടമാടിയിരുന്ന കേരളത്തിലെ സ്ത്രീ സങ്കല്പം തന്നെ അല്പം ലക്ഷണക്കേടുകളുണ്ടായിരുന്നു. കാര്യക്ഷമതയിൽ മന്ത്രിയെപ്പോലെയും ലാവണ്യത്തിൽ ലക്ഷ്മിയെപ്പോലെയും ക്ഷമയിൽ ഭൂമിദേവിയെപ്പോലെയും സ്നേഹ വാത്സല്യങ്ങളിൽ അമ്മയെപ്പോലെയും കിടപ്പറയിൽ വേശ്യയെപ്പോലെയും ആയിരിക്കണം ക്ലാസ്ത്രീയെന്ന് ആർഷഭാരതം പയ്യേക്കുപേ വിധിയെഴുതിയിരുന്നു. ഇതിഹാസങ്ങളും പുരാണങ്ങളും വിശ്വാസപ്രമാണങ്ങളും വെച്ചുകെട്ടി പ്രത്യുൽപ്പാദനത്തിനും ഉപഭോഗത്തിനും മാത്രമുള്ള കേവലശരീരങ്ങളായി സ്ത്രീയെ കൊടുന്ന ഭോഷതാം ഇന്ത്യയിലെ നടപ്പുശീലമായിരുന്നു. ഒരു കാലത്ത് നായർത്തറവാട്ടിലെ സ്ത്രീകൾക്കു തങ്ങളുടെ ഭർത്താവിന്റെ പേരുപോലും ഉച്ചരിക്കാനുള്ള അനുവാദം ഉായിരുന്നില്ല. അന്തർജ്ജനങ്ങളും ബ്രാഹ്മണികളും ശൂദ്രസ്ത്രീകളും ഒന്നിച്ച് ഭരണിനാൾ പണിയൊരുങ്ങിയിട്ട്, കാർത്തികനാൾ കാക്ക കരയും മുമ്പെ, മകീരത്തുനാൾ മക്കൾ ഉണരും മുമ്പെ തിരുവാതിരനാൾ ഗംഗയുണരും മുമ്പെ, ചന്ദനം, ചാന്ത്, കുങ്കുമം, കൺമഷി, അലക്കിയ വസ്ത്രം, നിലവിളക്ക് തുടങ്ങിയ മംഗളവസ്തുക്കളോടുകൂടി കുളക്കടവിൽ ചെല്ലും. ഗംഗയുണർത്തും, കുളംതുടിക്കും, പിന്നെയൊന്ന് തിരുവാതിര.

“പങ്കജാക്ഷൻ കടൽവർണ്ണൻ
വാസുദേവൻ ജഗന്നാഥൻ
നാരദാദി മുനിവരൻ
വന്ദിതൻ കൃഷ്ണൻ”

വാസുദേവന്റെ ഭാര്യയ്ക്കു നാവുപൊങ്ങിയില്ല. ചുവടും പിഴച്ചു. പിന്നെ ഒത്ത് ഒപ്പിച്ച് ഇങ്ങനെ പാടി;

“പങ്കജാക്ഷൻ കടൽ വർണ്ണൻ
കുഞ്ഞിന്റുച്ചൻ ജഗന്നാഥൻ”

ഇതായിരുന്നു കേരളത്തിലെ മധ്യവർഗ്ഗ പാരമ്പര്യത്തിലെ സ്ത്രീയുടെ ദുരവസ്ഥ. താഴേക്കിടയിലുള്ളവരുടെ കാര്യം അൽപം കൂടി ഭേദമാണെന്ന് പറയാതിരിക്കാനും തരമില്ല. കുടുംബത്തിനുള്ളിലുള്ളതിനേക്കാൾ സാമൂഹികമായ അടിച്ചമർത്തലുകളാണ് അത്തരം സ്ത്രീകളുടെ അധസ്ഥിതിക്ക് കാരണമെന്ന് നിരീക്ഷിക്കാൻ സാധിക്കും. ഇങ്ങനെ പുരുഷമേധാവിത്വങ്ങൾക്ക് അടിയറവു പറഞ്ഞുകൊണ്ട് സ്ത്രീ തന്റെ ജീവിതവും പ്രയത്നവും അടക്കമെടുക്കുന്നതിൽ അടക്കം ചെയ്തു; കാലങ്ങളോളം.

ഇരുപതാം നൂറ്റാണ്ടിന്റെ മധ്യത്തോടുകൂടി പടിഞ്ഞാറൻ നാടുകളിൽ ഉത്ഭവിച്ച വിപ്ലവത്തിന്റെ ചെങ്കൊടിക്ക് വളരാനുള്ള വളക്കൂറുള്ള മണ്ണായി നമ്മുടെ നാട് ഇതിനോടകം മാറിക്കഴിഞ്ഞിരുന്നു. അതിന്റെ ചലനങ്ങൾ സംസ്കാരത്തിലും സാഹിത്യത്തിലും പ്രതിഫലിച്ചു. കലാമൂല്യത്തേക്കാളേറെ ജീവിതമൂല്യങ്ങൾക്ക് പ്രാധാന്യം നൽകിയ സാഹിത്യ സൃഷ്ടികളിലേക്കു കടക്കാൻ ചെറുകാടിനെ പ്രേരിപ്പിച്ചതും ഈ വിപ്ലവബോധമാണ്.

മുത്തശ്ശിയിലെ പെണ്ണുങ്ങൾ

നാരകത്തു തറവാട്ടിലെ നാണിമിസ്ട്രസ്സ് തന്റെ ജീവിതം കൊും തൊഴിലുകൊും സമൂഹത്തിൽ സ്വന്തമായ ഒരിടം കണ്ടെത്തിക്കഴിഞ്ഞിട്ടു്. മരുമക്കത്തായ സമ്പ്രദായം നിലനിന്നിരുന്ന നായർ തറവാടുകളിൽ ഒറ്റപ്പെണ്ണായി ജനിക്കുന്നത് മഹാഭാഗ്യം തന്നെയാണ്. നാണിയമ്മയ്ക്ക് ആ ഭാഗ്യം സിദ്ധിച്ചിരുന്നു. തിരുകുളിയോടെ പഠനം നിർത്തി വരുമെന്നായപ്പോൾ മൂന്നു ദിവസം പട്ടിണികിടന്ന് മുത്തശ്ശിയിൽ നിന്ന് 8-ാം തരം വരെ പഠിക്കാനുള്ള സ്വാതന്ത്ര്യം നേടിയെടുത്തതാണ് നാണിയമ്മയുടെ വിപ്ലവജീവിതത്തിലെ ആദ്യത്തെ ചുവടുവെയ്പ്. സഹോദരനായ ബാലനാകട്ടെ കുടുംബ പ്രാരാബ്ദം മൂലം അഞ്ചാം തരത്തിൽ പഠനം നിർത്തിത്തെയും വന്നു. വിദ്യാഭ്യാസനായിത്തീർന്ന നാണിക്ക് തന്റെ സമൂഹത്തിലെ ദുരാചാരങ്ങളും നടപ്പുരീതികളും തെറ്റാണെന്ന തിരിച്ചറിവുവന്നു. ഒരു മാറ്റം ആവശ്യമാണെന്ന് മനസ്സിലാക്കുന്നു. പക്ഷേ, തീരുമാനങ്ങളെടുക്കാനോ ചിന്തിക്കാനോ കഴിയുന്നതിന് മുമ്പ് അൻപതിലധികം പ്രായമുള്ള കുട്ടപ്പൻനായരുടെ രാമ ഭാര്യയായ് മാറുന്ന ദുരവസ്ഥയാകുന്നു.

അദ്ദേഹത്തെ കാണുമ്പോൾ പൂച്ചയെ കാണുന്ന എലിയെപ്പോലെ ഒരു തെട്ടൽ! ഞാൻ അവിടെ ചെന്നപ്പോൾ എന്നെ അമ്മായി എന്നു വിളിച്ച രാമൻകുട്ടി നായർ എന്റെ ഭാവനയിൽ കടന്നുവന്നു അയാൾ അമ്മായി എന്ന് വിളിക്കുമ്പോൾ ലജ്ജകൊട് ഞാൻ അലിഞ്ഞുപോയി. എന്റെ ഭർത്താവകാൻ അയാളാണ് പാകം. എന്നിട്ടു വന്നതോ ഒരു തനകൊറ്റൻ! എന്റെ ഭാവനയിൽ ഒരു ചെറുപ്പക്കാരൻ കടന്നു വരികയാണ്. തലേദിവസം എന്നെ കാണാൻ കൂളത്തിങ്കൽ വന്നിരുന്ന അംബുജാക്ഷി. ചന്തമുള്ള ഒരു ജേഷ്ഠത്തി. അവർ എന്റെ ഭർത്താവിന്റെ ആദ്യത്തെ ഭാര്യയിലൂടെ സീമന്ത പുത്രിയാണ്. അവരെന്ന് ചെറിയമ്മ എന്ന് വിളിക്കുന്നു. ഈ വയസ്സുനേതാ എന്നെ കല്യാണം കഴിച്ചത്?. ഇയാൾ എന്റെ അമ്മയ്ക്കായിരുന്നെങ്കിൽ ഒരു വിധം ചേർച്ചയായിരുന്നു.- കേവലം പതിനാലു വയസ്സുമാത്രം പ്രായമായിരുന്ന നാണിയമ്മയുടെ ആവലാതികളാണിതൊക്കെ. ആ കാലഘട്ടത്തിലെ മധുവർഗ്ഗ മരുമക്കത്തായ തറവാടുകളിലെ സ്ത്രീ ജീവിതങ്ങളുടെ ചിത്രമാണ് ഇവിടെ കത്.

വിവാഹ ബന്ധത്തിൽ നിന്ന് രക്ഷപ്പെട്ട് അവൾ നാരകത്തു തറവാട്ടിലേക്കുതന്നെ തിരികെ വന്നു. കൊച്ചുമകളുടെ ഈ ധിക്കാരം മുത്തശ്ശിയെ കോപാകുലയാക്കി. കറിക്കത്തികൊട് നാണിയമ്മയുടെ ശിരസ്സിൽ ചോരപ്പാടുകൾ വീഴ്ത്തിയാണ് അവർ പ്രതികരിച്ചത്.

പരുത്തിക്കാട്ട് മനയ്ക്കലെ മൂന്നുറു പാട്ടത്തിന്റെ വെറുമ്പാട്ട കൃഷിയും അവയുടെ തന്നെ ജന്മമായ കുടിയിരിപ്പുമാണ് നാരകത്തെ തറവാട്ടുകാർക്ക് ആകെയുള്ള സ്വത്ത്. പാട്ട ബാക്കി കൊടുക്കാത്തതിന്റെ പേരിൽ നിയമനടപടിക്കൊരുങ്ങുന്ന മനയ്ക്കലെ കാര്യസ്ഥന്റെ തീരുമാനത്തെ എതിരിടാൻ മുത്തശ്ശിക്കത്തിയത് നാണിയമ്മയുടെ മാനത്തെയാണ്.

“നീയ് ഇനി അയാളെയും അപമാനിച്ച് പറഞ്ഞയച്ചാൽ ഞാൻ ഒലക്കയെടുത്ത് നിന്റെ കാല് തച്ചൊടിച്ചിടും..... എന്നിട്ട് വല്ല കാശിക്കോ രാമേശ്വരത്തേയ്ക്കോ അങ്ങ് നടക്കും.” മുത്തശ്ശിയുടെ ഈ ഭീഷണിക്ക് നാണിയമ്മ വഴങ്ങിയില്ല. മുത്തശ്ശിയുടെ ഈ ഭീഷണിക്ക് നാണിയമ്മ വഴങ്ങിയില്ല. കാശിരാമേശ്വരം യാത്രയെക്കുറിച്ച് നോവലിൽമറ്റൊരിടത്തും പരാമർശമു്. അതിനിടയായ സാഹചര്യം ഏറെ മാറ്റങ്ങൾക്കു ശേഷമുാവുന്നതാണ്.

മലബാറിലെ കോൺഗ്രസ്സ് സോഷ്യലിസ്റ്റു പാർട്ടി നടത്തിയ പ്രവർത്തനങ്ങളിൽ ജന്മിത്തത്തിന് എതിരെയുള്ള സമരങ്ങൾക്കും തൊഴിലാളിവർഗ്ഗ പ്രസ്ഥാനത്തിനും സാമ്രാജ്യത്വ വിരുദ്ധ പ്രക്ഷോഭങ്ങൾക്കും ഒപ്പം തന്നെ മഹിളാ സംഘടനകളും അധ്യാപക സംഘടനകളും രംഗത്തുവരികയായി. നോവലിലെ നാണിയമ്മ ഇതിന്റെയൊക്കെ ഭാഗമാകുന്നു്. ബോധനശാസ്ത്രം ആധികാരികമായി അഭ്യസിച്ച് അധ്യാപികയായിത്തീർന്ന നാണിമിസ്ട്രസ്സ് തന്റെ സഹപ്രവർത്തകരായിരുന്ന ചാത്തുനായർക്കും രാധാകൃഷ്ണമേനോനും ഒപ്പം അധ്യാപക സംഘടനയിലും പ്രവർത്തിച്ചു തുടങ്ങി. സ. കിടാവും സ. ഗോപാലനും വനിതാ സംഘടന ഉാവേതിന്റെ ആവശ്യകതയെക്കുറിച്ച് നാണിമിസ്ട്രസ്സിനെ ബോധ്യപ്പെടുത്തിക്കൊടുത്തു.

“ഒരു സംഘടന ഉാക്കുവാൻ തുടങ്ങുന്ന പൊതുപ്രവർത്തകനോ പ്രവർത്തകയോ ആമുന്നണിക്ക് പൊതുവെയുള്ള അവശതകൾ പഠിക്കുകയും അത് തീർക്കുവാനുള്ള വഴികളൊരുക്കുകയും ഒരു ലക്ഷ്യത്തിലെത്താനുള്ള ബോധം മുന്നണിക്ക് ഉാക്കിക്കൊടുക്കുകയുമാണ് ആദ്യം ചെയ്യേത്.” -എന്ന സഖാവ് കിടാവിന്റെ ഉപദേശം ചെറുകാട് -എന്ന രാഷ്ട്രീയ പ്രവർത്തകന്റെ, അധ്യാപകന്റെ ബോധപൂർവമുള്ള ഇടപെടലായിട്ട് വിലയിരുത്താവുന്നതാണ്.

“കിടാവു പറഞ്ഞത് ശരിയാണെന്ന് എനിക്കുതോന്നി. എനിക്ക് മീശമുളച്ചതുപോലെ. ഞാൻ ഒറ്റപ്പെട്ട് നിൽക്കുകയാണ്. ഞാൻ സാധാരണ സ്ത്രീകളിൽ നിന്ന് ഒറ്റപ്പെട്ടുനിൽക്കുന്നു. ഒരു പുരുഷ മണ്ഡലത്തിൽ തലയും മുലയുമുള്ള പുരുഷനായി ജീവിക്കുന്നു. ഈ നില മാറ്റാതിരുന്നാൽ മോശമാണ്. ഞാൻ തീരുമാനിച്ചു.”

സ്ത്രീകൾക്ക് അവശതകളും അറിവു പകർന്നു നൽകുന്നതിലൂടെ അതിനു മാറ്റമുണ്ടാക്കാമെന്നും ക്ക സംഘടനാപ്രവർത്തനത്തിനുള്ള മാർഗ്ഗമായി വായനശാല സജീവമാക്കാൻ ശ്രമിച്ചു. ഒപ്പം വനിതാസംഘവും രൂപീകരിച്ചു. മുത്തശ്ശിയിലെ മുത്തശ്ശി മരുമക്കത്തായ തറവാട്ടിലെ എല്ലാ ദുരവസ്ഥകളുടെയും പ്രതിബംബമാണ് നോവലിന്റെ തുടക്കത്തിൽ പ്രത്യക്ഷപ്പെടുന്നത്.

“മുത്തശ്ശിമാർ എന്തൊരു വിലങ്ങുതടികളാണ്. ഞാൻ ആലോചിച്ചു. അവർ സ്നേഹത്തിന്റെ ചങ്ങലകെട്ട് പുതിയ തലമുറയെ പിന്നോട്ട് വലിക്കുകയാണ്. കുതിച്ച് മുന്നോട്ടു നീങ്ങാൻ കെൽപ്പുകളിൽ അവരെയും കെട്ട് മുന്നോട്ട് നീങ്ങാം.” - നാണിമിസ്ട്രസ്സ് തന്റെ അതേജീവിത സാഹചര്യത്തിൽ കഴിയുന്ന ദേവയാനിയെ ഉപദേശിച്ചു.

പാട്ടു ബാക്കി കൊടുക്കാത്തതിന്റെ പേരിൽ തന്റെ കുടുംബം ജന്മിത്തത്തിന്റെ കൊടും ക്രൂരതകളിലേക്ക് കടന്നുപോകുന്നു എന്ന കാര്യം കൊച്ചുമകളായ നാണിമിസ്ട്രസിലൂടെ അവർക്ക് ബോധ്യപ്പെട്ടു. ആ കാലഘട്ടത്തിലെ കർഷകപ്രസ്ഥാനങ്ങൾ പാട്ടം കുറിക്കുന്നതിനും ഒഴിപ്പിക്കൽ തടയുന്നതിനും ഒപ്പം ജന്മിത്തം അവസാനിപ്പിക്കുന്നതിനും കൂടി സമരം ചെയ്തിരുന്നു. 1939-40 കാലത്ത് കുട്ടികൃഷ്ണമേനോൻ കമ്മിറ്റി കൂടിയാൽ പ്രശ്നങ്ങളെക്കുറിച്ച് അന്വേഷണം നടത്തി. ജന്മിമാരുടെ മർദ്ദനങ്ങൾക്കും ക്രൂരതകൾക്കും അക്രമ പിരിവുകൾക്കുമെതിരായ പോരാട്ടങ്ങൾ പാട്ടു നിഷേധ സമരത്തിലേക്ക് കർഷകരെ എത്തിച്ചു. മുത്തശ്ശിയിലും ഇതിന്റെ പ്രതിഫലനം കാണാം.

തൊഴിലാളി നേതാവായ ബാലനെ ഒളിവിൽവെച്ചുവെന്ന കുറ്റം ചാർത്തി പൂർണ്ണ ഗർഭിണിയായ നാണിയമ്മയെയും ഭാര്യയായ കുഞ്ഞിമാളുവിയനെയും ജയിലിലടച്ചു. ഒരുവേല മുത്തശ്ശിക്കും അതിനുള്ള യോഗ്യമായി. മുത്തശ്ശിയെ കൊടുപോകാൻ പോലീസുകാരെത്തി. അവർ മുത്തശ്ശിയെ പിടിച്ചുവലിച്ചപ്പോൾ

“എന്താ ഇത് വലിക്കണത്? ഞാൻ വല്ല പയ്യോ മുരിയോ മറ്റോ ആണോ?” എന്ന് ആ വൃദ്ധ തിരിച്ചു ചോദിച്ചു.

ഒളിവിൽ കഴിയുന്ന ചെറുമകന്റെ രഹസ്യങ്ങൾ പറഞ്ഞുകൊടുത്താൽ നൂറുറൂപ്പിക തരാമെന്ന് മറ്റൊരു പോലീസുകാരൻ പറഞ്ഞു.

അതിനുള്ള മറുപടി; “ആ തോട്ടിൽ കൊട്ടി ചിറകെട്ടിക്കോ” - എന്നായിരുന്നു.

മുത്തശ്ശിയുടെ ജയിൽ വാസകാലത്തെ കഥകൾ ജയിലിലെ പെൺ വാർഡനായ കുഞ്ഞായിശുമ്മ നാണിയെ അറിയിക്കുന്നു. “വല്ലാത്തൊരു പടപ്പാടാണ് ഓലി. ശീച്ചിച്ചപ്പോ ചിരിക്കാ. അപ്പൊ മജിസ്ട്രേറ്റ് ചോദിച്ചു, എന്തിനാ ചിരിക്കണത് എന്ന്. അപ്പൊ പറഞ്ഞു തള്ളയ്ക്ക് സന്തോഷായിന്ന്. കാളിരാമേശ്വരം പോ കാലത്താണ് കണ്ണൂരെങ്കിലും ഒന്നുപോവാല്ലേന്ന്. മുപ്പരും ചിരിച്ചു.” (മുത്തശ്ശി 537 പേജ്) ഇങ്ങനെ അനിവാര്യമായ സമരസാഹചര്യങ്ങളെ ഒരു മടിയും കൂടാതെ ഏറ്റുവാങ്ങാൻ അവർ തയ്യാറാകുന്നു. സ. ഗോപാലനും സ. കിടാവിനുമൊക്കെ ഒളിവിൽ പാർക്കാൻ നാരകത്തു തറവാട് തുറന്നു കൊടുത്തു.

സ്ഥാലന്റെ ഉമ്മ മറ്റൊരു ശക്തയായ സ്ത്രീ കഥാപാത്രമാണ്. ബാലൻ ഒളിവിൽ പോയ കാലത്ത് അയാളുടെ ഭൃമിയിൽ കൃഷിപ്പണി ചെയ്തിരുന്ന സ്ഥാലനെ പോലീസ് പിടികൂടി. ബാലനെ കാട്ടിക്കൊടുക്കാത്തതിന്റെ പേരിൽ അയാളെ മർദ്ദിച്ച് അവശനാക്കി. മേലിൽ ബാലന്റെ ഭൃമിയിൽ പണിയെടുക്കരുതെന്ന് താക്കീതും നൽകി. എന്നാൽ സ്ഥാലന്റെ ഉമ്മ അതിന് നിന്നു കൊടുത്തില്ല. കക്കാനും പിടിച്ചു പരിക്കാനും പോണില്ല. പിടിച്ചുകൊണ്ട് പോകുന്നവർ ചിലവിനും കൊടുക്കില്ല. പിന്നെ എന്തിനു ഞാൻ പണിക്കു വരാതിരിക്കണം. വിദ്യാഭ്യാസമോ സാമൂഹിക പരിജ്ഞാനമോ ഒന്നുമില്ലാതിരുന്നിട്ടും അവർ സ്വന്തം തീരുമാനം തുറന്നു പറഞ്ഞു.

ബാലന്റെ ഭാര്യ കൗമാരക്കാരിയാണ്. വിദ്യാഭ്യാസം കുറവാണ്. മുറച്ചെറുക്കനായ ബാലനെ വിവാഹം കഴിക്കി വന്നു. അതിൽ അവൾക്ക് യാതൊരു എതിർപ്പും ഉായിരുന്നില്ല. എന്നാൽ തൊഴിലാളി നേതാവായ ബാലനെ അറസ്റ്റുചെയ്യാൻ അധികാരി വർഗ്ഗം തയ്യാറാവുന്നു. അയാൾ ഒളിവിൽ പോകുന്നു. തുടർന്ന് ജീവിതം പ്രതിസന്ധിയിലകപ്പെട്ടപ്പോൾ ബാലന്റെ ഭാര്യയായ കുഞ്ഞിമാളുവിയനെ മറ്റൊരു

വിവാഹത്തിന് പ്രേരിപ്പിക്കുന്നു. ഇഷ്ടമുള്ള പുരുഷനെ ഉപേക്ഷിച്ച് ഇഷ്ടമില്ലാത്ത ഒരാളുടെ ഭാര്യയായി നിൽക്കേ വരുന്നതിലും ഭേദം മരിക്കുകയാണെന്ന നിലപാടാണ് കുഞ്ഞിമാളു സ്വീകരിക്കുന്നത്. പിതൃഅധികാര വ്യവസ്ഥയ്ക്കുള്ളിൽ തന്റെ ദാമ്പത്യത്തെ മുന്നോട്ടു കൊണ്ടുപോകാൻ തത്രപ്പെടുന്ന കുഞ്ഞിമാളു ഒരു ഉദാഹരണം മാത്രമാണ്. ഒളിവിൽ കഴിഞ്ഞ കാലത്ത് ബാലൻ താമസിക്കുന്നത് അമ്മുവിന്റെ ആദ്യഭാര്യയുടെ വീട്ടിലാണ്. മുസ്ലീംസമുദായത്തിലെ സ്ത്രീകൾ അനുഭവിക്കുന്ന പ്രശ്നങ്ങളുടെ പ്രതീകമാണ് ആ സ്ത്രീകൾമാത്രം ബാലനെ സംരക്ഷിക്കുന്നതിലൂടെ അവരും ഒരു സാമൂഹിക കടമ ഏറ്റെടുക്കുകയായിരുന്നു.

മാറു മറയ്ക്കാനും കുപ്പായമിടാനും സ്വാതന്ത്ര്യമില്ലാത്ത, ജാതീയതയുടെ തിക്താനുഭവങ്ങളിലൂടെ കടന്നുപോകുന്ന, പുരുഷവർഗ്ഗ മേൽക്കോയ്മയിൽ അടങ്ങിയൊതുങ്ങി കഴിയുന്ന ദരിദ്രാവസ്ഥയിൽ പട്ടിണികിടക്കുന്ന വേറെയും സ്ത്രീകൾമാത്രങ്ങൾ മുത്തശ്ശിയിൽ മിന്നിമറയുന്നു.

വർത്തമാനസാഹചര്യവും മുത്തശ്ശിയും.

മുത്തശ്ശി കൈകാര്യം ചെയ്ത സ്ത്രീപക്ഷ വായന കാലിക പ്രസക്തിയുള്ളതാണ്. പാരമ്പര്യം കൊണ്ട് പാരമ്പര്യത്തെ തോൽപ്പിച്ച മുത്തശ്ശിയും അക്ഷരവിദ്യകൊണ്ട് വിരുതുകാട്ടിയ നാണിമിസ്ട്രസും കേരളത്തിലെ ഇന്നത്തെ സാഹചര്യത്തിലും പുനർജനിക്കേവരാൻ.

മനസ്സിൽ മൃഗീയമായ കാമഭ്രാന്തുമായി അധികാരത്തിന്റെ പിൻബലമുപയോഗിച്ച് നാണിയെ കടന്നുപിടിക്കാൻ ശ്രമിച്ച സഹപ്രവർത്തകനെ അവൾ ഊക്കോടെ തള്ളിയിട്ടു കടന്നുപോയി. അവതുകളുടെ മധ്യത്തിൽ തന്റെ സാഹിത്യകൃതിയിലൂടെ ചെറുകാട് പ്രതിരോധിക്കാനുള്ള പെണ്ണിന്റെ ചങ്കുറ്റത്തെ പ്രോത്സാഹിപ്പിക്കുകയായിരുന്നു. സ്ത്രീപീഡനങ്ങൾ വർദ്ധിക്കുന്ന ഈ കാലത്ത് ചെറുകാടിലെ ദീർഘദർശി നമ്മെ ചിന്തിപ്പിക്കുകയാണ്.

അമ്മായിപ്പഴമയുടേയും അമ്മായി ശാസ്ത്രത്തിന്റെയും ചുവടുപിടിച്ച് പെണ്ണിനുമേൽ അരുതുകളുടെ വിലക്കുകളുടെ കുരുക്കിടുമ്പോൾ നേരും നെറിയും കഞ്ഞി പ്രവർത്തിക്കാൻ നാണിമിസ്ട്രസ് പ്രോത്സാഹിപ്പിക്കുന്നു.

അൻപതുകളിലെ സാഹചര്യമല്ല ഇപ്പോഴുള്ളതെങ്കിലും അസമത്വത്തിന്റെ രൂപഭേദങ്ങൾ ഒളിഞ്ഞും തെളിഞ്ഞും സമൂഹത്തിലിപ്പോഴുമുണ്ട്. ശരി തെറ്റുകൾ നിർമ്മിക്കുന്നത് അവരാണ്. പെണ്ണി എന്ത് ഉണ്ണണമെന്നും എന്ത് ഉടുക്കണമെന്നും എന്ത് സംസാരിക്കണമെന്നും തീരുമാനിക്കുന്ന വ്യവസ്ഥിതികളെ സംശയത്തോടെ കാണുകയും സമത്വബോധത്തോടെ അവയെ വിശകലനം ചെയ്ത് ജീവിതനിലവാരം മെച്ചപ്പെടുത്താനും സോഷ്യലിസ്റ്റു സ്ത്രീവാദം, അതിന്റെ വിശാലമായ വീക്ഷണത്തിലൂടെ ബോധ്യപ്പെടുത്തിക്കൊരിരിക്കുന്നു.

സഹായഗ്രന്ഥങ്ങൾ

1. സ്ത്രീ ജീവിതം, സംസ്കാരം	- ജാനമ്മ കുഞ്ഞുണ്ണി
2. കമ്മ്യൂണിസ്റ്റ് മാനിഫെസ്റ്റോ	- കാൾമാർക്സ് ഫ്രെഡറിക് ഏംഗൽസ്, ദക്ഷിണേന്ത്യ പഠനകേന്ദ്രം തിരുവനന്തപുരം.
3. സ്ത്രീ എഴുത്തും വിവേചനവും	- പ്രൊഫ. വി. സുകുമാരൻ ചിന്ത പബ്ലിക്കേഷൻസ്, തിരുവനന്തപുരം, 2011
4. കമ്മ്യൂണിസ്റ്റ് പ്രസ്ഥാനം കേരളത്തിൽ	- സി. ഭാസ്കരൻ, ചിന്ത പബ്ലിക്കേഷൻസ്, തിരുവനന്തപുരം, 2013
5. കേരളത്തിലെ കമ്മ്യൂണിസ്റ്റ് പ്രസ്ഥാനം ഉത്ഭവവും വളർച്ചയും	- ചിന്ത പബ്ലിക്കേഷൻസ്, തിരുവനന്തപുരം, 2008.
6. മഹിളാരംഗത്തെ കടമകൾ സി.പി. ഐ (എം) നയരേഖ	- ചിന്ത പബ്ലിക്കേഷൻസ്
7. മുത്തശ്ശി	- ചെറുകാട്, കേരളസാഹിത്യ അക്കാദമി, തൃശ്ശൂർ

സ്ത്രീവാദത്തിന്റെ സ്വാധീനം ടൂലേറ്റിൽ

മലയാളചെറുകഥയിൽ സ്ത്രീപക്ഷവാദത്തിന്റെ കരുത്ത് തെളിയിച്ച എഴുത്തുകാരിൽ പ്രമുഖമാണ് ചന്ദ്രമതി. സ്ത്രീയ്ക്കും പുരുഷനും സമൂഹത്തിൽ തുല്യസ്ഥാനം ലഭിക്കണമെന്ന തന്റെ അഭിലാഷത്തിന്റെ തെളിവുകളാണ് അവരുടെ കഥകൾ. പ്രമേയ വൈവിധ്യംകൊണ്ടും ആഖ്യാനശൈലിയുടെ വ്യത്യസ്ഥതകൊണ്ടും ചന്ദ്രമതിയുടെ കഥകൾ ഇതര കഥകളിൽ നിന്നും വ്യത്യസ്തമാകുന്നു. നിറഞ്ഞ സ്വാഭാവികതയുടെ സ്ത്രീയും പുരുഷനും ചേർന്നു കഴിയുന്ന കുടുംബവൃത്തത്തിലെ വ്യവഹാരങ്ങൾ തെളിവോടെ ഒപ്പിയെടുത്ത് അവതരിപ്പിക്കാൻ ചന്ദ്രമതി ശ്രമിക്കുന്നു. പെൺമനസിലെ സകല ചൈതന്യത്തെയും കോർത്തിണക്കി പ്രതിരോധത്തിലേക്ക് പരിവർത്തിപ്പിയ്ക്കുന്ന ഒരു സ്ത്രീയുടെ കഥ ആവിഷ്കരിക്കുകയാണ് ചന്ദ്രമതി ടൂലേറ്റ് എന്ന കഥയിലൂടെ.

കഥാകാരിയുടെ തന്നെ മാനസികഭാവത്തിനനുരൂപമായി കഥാപാത്രത്തെ അവതരിപ്പിച്ചിരിക്കുന്ന ഒരു കഥയാണ് ടൂലേറ്റ്. പഴയബിംബങ്ങൾ ഉപയോഗിക്കുന്നതിനാൽ ആവർത്തന വിരസത തോന്നാം എന്നതിനാൽ ക്ഷമാപണം നടത്തിക്കൊണ്ട് കഥാകാരി കഥയിലേക്ക് പ്രവേശിക്കുന്നു. “കുത്തിയൊഴുകി മരിക്കുന്ന തിരമാലകൾക്കിടയിൽ ആലംബമില്ലാതെ ഉലയുന്ന തോണി വളരെ പഴയൊരു കഥബിംബമാണ്. എങ്കിലും ചില പ്രത്യേക സന്ദർഭങ്ങളിൽ പഴയബിംബങ്ങൾ ഉപയോഗിക്കാതെ വയ്യ. ഈ കഥയിൽ അവളുടെ മാനസികാവസ്ഥ വിശദീകരിക്കുവാൻ സ്വയം ഒഴുകിവന്ന ബിംബം ഇതാണ്” 1.

കഥാപാത്രത്തിന്റെ പേര് ഒരിക്കൽപോലും പറയാതെ അവൾ എന്ന പ്രഥമപുരുഷ വീക്ഷണത്തിലൂടെ കഥ പറഞ്ഞുപോകുന്ന കഥാകാരി തന്നിലും അളവിലും സാമ്യതകണ്ടാൻ ശ്രമിക്കുന്നു. “എന്റെ മനസ്സുതന്നെയാണല്ലോ അവളുടെ കിടക്കമുറി, അവളുടെ വീട്, അവളുടെ ജീവിതെ എല്ലാം” 2 എന്ന കഥാകാരിയുടെ തന്നെ അഭിപ്രായപ്രകടനത്തിലൂടെ അനുവാചകന് അത് കൂടുതൽ വ്യക്തമാകുന്നു. ഇളകിയുയർന്ന് അക്രമാസക്തമാകുന്ന തിരമാലകൾക്കിടയിൽ ഇപ്പോൾ മുങ്ങുമെന്നമട്ടിൽ ഉലയുന്ന ചെറുതോണിപോലെയാണ് ടൂലേറ്റിലെ കഥാപാത്രത്തിന്റെ ജീവിതെ. നിശബ്ദത നിഴലിക്കുന്ന രംഗചിത്രീകരണവും നിഷ്ക്രിയതയുടേക്ക് അനുവാചകരെ ഒന്നടങ്കം പിടിച്ചിരുത്തുവാൻ ഈ കഥയ്ക്ക് കഴിഞ്ഞു.

ചുരുക്കം ചില കഥാപാത്രങ്ങളുടെ ചിത്രീകരണത്തിലൂടെ ഇന്നത്തെ സമൂഹത്തിൽ സ്ത്രീകൾ അനുഭവിക്കേണ്ടി വരുന്ന പീഡനങ്ങൾക്ക് നേരെ വിരൽചൂകയാണ് കഥാകാരി. പുരുഷന്റെ കാമരൂപണത്തിനുവേിയുള്ള ഉപാധിയായി മാത്രം സ്ത്രീയെ കാണുന്ന സമൂഹത്തോട് തങ്ങൾക്കും ചിലത് പറയാനും പ്രവർത്തിക്കാനും ഉ് എന്ന ബോധ്യമുള്ളവരായെന്ന തരത്തിലുള്ള കഥയാണിത്. കുട്ടികളുടെയും ഭർത്താവിന്റെയും താള

പാർവ്വതി കെ.ജി.
ഗവേഷക
മലയാളവിഭാഗം
എൻ.എസ്.എസ്. കോളേജ്
നിലമേൽ, കൊല്ലം

ത്തിനനുസരിച്ച് രാത്രിയിലും രാവിലെയും ഓരോ വേഷംകെട്ടിയാടേിവരുന്ന സ്ത്രീസമൂഹത്തിന്റെ ഉന്നമനം ലക്ഷ്യമാക്കിക്കൊള്ളതാണ് ഈ കഥ. കഥയുടെ ഓരോ ഭാഗത്തിലൂടെയും കടന്നുപോകുമ്പോൾ കഥാകാരിതന്നെ കഥാപാത്രം എന്ന് അനുവാചകർക്ക് തോന്നിപ്പോകും. “ഉറക്കയിൽ അവൾ ആ ചിത്രം തലയണക്കീഴിലോളിപ്പിച്ചു വെച്ചത് അവളുടെ ഭർത്താവ് അറിഞ്ഞില്ലെങ്കിലും ഞാനറിഞ്ഞു. ഞാനറിയാതെ അവൾക്കൊന്നും ചെയ്യാനാവില്ലല്ലോ”. 3

ഗാർഹിക ജോലികളിൽ നിന്നും മുക്തിനേടാൻ കഴിയാത്ത ഒരു സ്ത്രീയുടെജീവിതമാണ് കഥാകാരി നമുക്കു മുന്നിൽ അവതരിപ്പിക്കുന്നത്. കുട്ടികളെയും ഭർത്താവിനെയും യാത്ര അയച്ചിട്ട് അവൾക്കും ഓഫീസിൽ പോകേ തായിട്ടു്. ഓഫീസിൽ പോകുന്നതിനിടയിലും അവൾ പത്രം നോക്കി സമയം കെത്താറു്. കുടുംബത്തിലും സമൂഹത്തിലും ഒറ്റപ്പെടുന്ന അവൾക്ക് പത്രം എന്നും ഒരു ആശ്വാസമായിരുന്നു. ആയതിനാൽതന്നെ പത്രത്തിനും അവളോട് എന്തെക്കെയോ പറയാനാകും. കഥയിൽ ഒരു ബിംബമായി വർത്തിക്കുന്ന പത്രത്തിൽ വന്ന ഒരു വാർത്ത അവളെ അസ്വസ്ഥയാക്കുന്നതിൽ നിന്നാണ് കഥയിൽ വഴിത്തിരിവുകൾ ഉാകുന്നത്. പത്രത്തിലെ ഒന്നാം പേജിൽ വന്ന നിഷേധവാർത്തയിൽ നിന്ന് കഥാകാരി കഥയുടെ കേന്ദ്രത്തിലേക്ക് പ്രവേശിക്കുന്നു. വഴിയരികിൽ തളർന്നു വീണ ഭിക്ഷക്കാരിയെക്കുറിച്ചുള്ളതായിരുന്നു. ആ നിഷേധവാർത്ത. ചീറിപ്പായുന്ന വാഹനത്തിൽ ഇരിക്കുന്നവരോ, കാൽനടക്കാരോ അവരെ ആശുപത്രിയിലാക്കാൻ തയ്യാറാകാത്തതിൽ പത്രം രോക്ഷംകൊള്ളുന്നു.. ‘ആർക്കു പണയം നമ്മുടെ മനസ്സാക്ഷി’ എന്ന അടിക്കുറുപ്പോടെ വന്ന വാർത്ത പത്രത്തെപ്പോലെ തന്നെ കഥാകാരിയിലും രോക്ഷം ഉാക്കിയ ആഫോട്ടോ എടുക്കുന്ന നേരം കെട് ആ പത്രക്കാരന് അവരെ ആശുപത്രിയിലാക്കിക്കൂടായിരുന്നോ എന്ന് കഥാനായിക സ്വഭാവികമായും ചിന്തിന്നു. പത്രക്കാരന്റെ മനസാക്ഷിയും പണയത്തിലായിരിക്കും എന്ന് അവർ ചിന്തിച്ചത് സ്വന്തം അവസ്ഥയെക്കുറിച്ച് ഓർത്തതുകൊാകാം. പത്രത്തിന്റെ പേജുകളിൽ നിന്നും പേജുകളിൽ നിന്നും പേജുകളിലേക്ക് സഞ്ചരിച്ച അവളുടെ കണ്ണുകൾ ‘സ്നേഹനിധിയായ മോഹൻ ഞങ്ങളെ വിട്ടുപിരിഞ്ഞുപോയിട്ട് ഇന്ന് ഒരു വർഷം എന്ന തലക്കെട്ടിൽ ഉടക്കി ആ വാർത്ത അവളിലാക്കിയ നടക്കും അന്തരീക്ഷത്തിലാക്കിയ മാറ്റം പോലും അവളെ അറിയിക്കാൻ പ്രാപ്തമായില്ല.

പരേതനെക്കുറിച്ചുള്ള വാർത്ത തന്റെ ഭൂതകാലസ്മൃതിയിലേക്ക് കഥാനായികയെ കുട്ടിക്കൊപ്പോകുന്നു. ഒന്നു കരയാൻ പോലും സ്വാന്ത്ര്യമില്ലായിരുന്ന അവൾ ഒരുതരം മുതാവസ്ഥയിലായി. ഓഫീസ് ജോലികളിൽ നിന്നും അവധിയെടുക്കുന്നതുപോലെ ഗൃഹജോലികളിൽ നിന്നും അവധിയെടുക്കാൻ കഴിയാത്തതുകെട് അവൾക്ക് സ്വയം നിയന്ത്രിക്കേിവന്നു. മണിക്കൂറുകൾ കെട് അവൾ വിശപ്പറിയാതെ, ദാഹമറിയാതെ വർഷങ്ങളിലൂടെ സഞ്ചരിക്കുകയായി.

കഥാനായികയുടെ ഭർത്താവിന് ജലദോഷമായതിനാൽതന്നെ അന്നത്തെദിവസം രാത്രിയിൽ അയാൾ പ്രാപിക്കാത്തത് അവൾക്ക് കൂടുതൽ ആശ്വാസമായിരുന്നു. തങ്ങളുടെ അസ്വസ്ഥതകൾ പരിഗണിക്കുകയും സ്ത്രീകളുടെ കില്ലെന്ന് നടക്കുകയും ചെയ്യുന്ന പുരുഷസമൂഹത്തിന്റെ പ്രതിനിധിയാണ് കഥാനായികയുടെ ഭർത്താവ് രാത്രിയുടെ യാമളും അവൾ മോഹൻ എന്ന പരേതനെക്കുറിച്ചാലോചിച്ചുകെട് തികച്ചും അസ്വസ്ഥയായി.

ഭാര്യയാകുന്നതിനും അമ്മയാകുന്നതിനും മുമ്പ് കഥാനായിക മോഹൻ എന്ന യുവാവിന്റെ കാമുകിയായിരുന്നു എന്ന് അനുവാചകർ അറിയുന്നത് ഈ അവസരത്തിലാണ് തിരുവനന്തപുരത്തെ പബ്ലിക് ലൈബ്രറിയിലും മൃഗശാലയിലുമൊക്കെ അവളുടെ ചിന്തകളെല്ലാമുടെ കടന്നുപോയി. മൃഗശാലയിലെ ജീവജാലങ്ങളുടെ അനുഗ്രഹാശ്ശിസുകളോടെ അയാളുടെ സ്പർശങ്ങൾ അവളിലേക്ക് വഴുതി വീണതുമുതൽ സ്ത്രീ എന്ന നിലയിൽ അവൾ ചുഷണം ചെയ്യപ്പെടുകയായിരുന്നു. കോഴിക്കറി ഇഷ്ടപ്പെടുന്ന അവനും തികച്ചും സസ്യഭുക്കായ അവളും തമ്മിലുള്ള വ്യത്യാസം മാത്രം മുന്നിൽക്കാണുന്ന സമൂഹത്തിനെതിരെ കലഹിക്കുകയാണ്.

വിദ്യാഭ്യാസവും വിവരവും ഉായിരുന്ന കഥാനായിക ഈ പെൺകുട്ടികൾ എത്ര സിദ്ധിയാണ് എന്ന കാമുകന്റെ ചോദ്യത്തിനുമുന്നിൽ തളരാതെ സ്വന്തം സ്ത്രീത്വത്തെ ഉയർത്തിക്കാട്ടുന്നു. ഭരണരംഗത്തേക്ക് തിരിയാനുള്ള തന്റെ അഭിലാഷത്തെ കഥാനായിക കാമുകനായ മോഹനനോട് പറയുമ്പോൾ ‘വേ, ഭാര്യയും ഭർത്താവും ഒരേ പ്രൊഫഷനായാൽ ശരിയാകില്ല. പ്രത്യേകിച്ച് എക്സ്ട്രാ ടെൻഷനുള്ള ഐ.എ.എസ് ജോലി എന്ന ഉത്തരമാണ് അവൾക്ക് ലഭിക്കുന്നത്. വിട്ടുവീഴ്ചയ്ക്കുള്ള മനോഗതി പൊതുവെ അവൾക്ക് ലഭിക്കുന്നത്. വിട്ടുവീഴ്ചയ്ക്കുള്ളമുള്ള മനോഗതി പൊതുവെ സ്ത്രീകൾക്ക് സ്വായത്തമായതു

കെട്ട് ഗവേഷണ രംഗത്തേയ്ക്ക് തിരിയാനുള്ള അവളുടെ തീരുമാനത്തെ മോഹൻ എന്ന യുവാവ് ശരി വെയ്ക്കുന്നു.

തന്റെ കഠിനപ്രയത്നം കെട്ട് ഗവൺമെന്റ് തിരഞ്ഞെടുത്ത അധ്യാപകരുടെ ലിസ്റ്റിൽ കഥാനായി കയുടെ പേര് ഒന്നാമതായി വന്നപ്പോൾ ഭാര്യ ജോലിക്ക് പോകുന്നത് തനിക്ക് ഇഷ്ടമല്ലെന്നും വിവാഹം വരെ ആയിക്കോളൂ എന്നും മോഹൻ പറയുന്നു. കഥാനായികയുടെ വ്യക്തിത്വത്തെ ഘനിക്കുന്ന ഉത്തരമായിരുന്നു മോഹന്റെ നാവുകളിൽ നിന്നും വന്നത്. സ്ത്രീത്വത്തെ അബലയായി കൂവന്ന പുരുഷസമൂഹത്തിന്റെ പ്രതിനിധിയായ മോഹന്റെ വാക്കുകളുടെ മുർച്ചയിൽ തളരാതെ സർവ്വശക്തിയുമെടുത്ത് തന്റെ സ്വത്വം ഉറപ്പിച്ചുറപ്പിക്കുന്നതായിരുന്നു കഥാനായികയുടെ അപ്പഴത്തെ മറുപടി. ജോലി കഴിഞ്ഞത്തുന്ന് ഭർത്താവിനെ കാത്ത് ഒരു കപ്പ് ചുടുചായയുമായി വാതിൽക്കൽ നിൽക്കുന്ന ഭാര്യയാവാൻ തനിക്കു കഴിയില്ല എന്ന വസ്തുത തന്റേടത്തോടെ തന്നെ കഥാനായിക പറയുന്നു. ചൂഷണത്തിലും വീര്യനത്തിലും മനം നൊന്ത് കഴിയുന്ന സ്ത്രീസമൂഹത്തിന്റെ ഉന്നമനത്തിനുവേിയുള്ളവയാണ് കഥാനായികയുടെ ഇപ്രകാരമുള്ള വാക്കുകൾ എന്ന് നിസ്സംശയം പറയാൻ കഴിയും . വായന, ക, കവിത എന്നിവയൊക്കെ പ്പോരെ എന്നും വ്യക്തിത്വം വളർത്താൻ ഒരു ഓഫീസ് വേണമെന്നില്ല, വീടുമാകാം എന്നും മോഹൻ തിരിച്ചടിച്ചു. സ്ത്രീയുടെ ജീവിതം വീടെന്ന നാലുചുവരുകളിൽ ഒതുക്കാനുള്ളതാണെന്ന പരമ്പരാഗത വിശ്വാസം വച്ചുപുലർത്തിയിരുന്ന മോഹൻ എന്ന യുവാവ് തന്റെ തലമുറയെ പ്രസവിക്കാനും നോക്കിവളർത്താനുള്ള ഒരു ഉപകരണം മാത്രമായി സ്ത്രീസമൂഹത്തെ കാണുന്നു. സ്ത്രീയെക്കുറിച്ച് മോഹന്റെ സങ്കല്പങ്ങൾ അവർ തമ്മിലുള്ള വിശ്വാസത്തിന്റെ അടിവേരുകൾ പിളർക്കുന്നതായിരുന്നു. മോഹന്റെ തന്റെ അമ്മയോടുള്ള ആത്മബന്ധത്തിന്റെ തെളിവുകൾ നിരത്തിയാണ് തന്റെ നിലപാടുകൾ വ്യക്തമാക്കിയത്. തന്റെ അമ്മയ്ക്കായിരുന്ന ജോലി രാജിവെച്ചിട്ടാണ് അച്ഛൻ അവരെ വിവാഹം കഴിച്ചതെന്നും കുട്ടികൾക്ക് അമ്മയോടുള്ള ആത്മബന്ധം നിലനിർത്താൻ ജോലി ഉായിരിക്കരുത് എന്നുമാണ് മോഹന്റെ അഭിപ്രായം. രാവിലെ തിരക്കിട്ട് ജോലിക്ക് പോവുകയും വൈകിട്ട് ക്ഷീണിച്ചെത്തുകയും ചെയ്യുന്ന ഒരു സ്ത്രീക്ക് തന്റെ അമ്മയെപ്പോലെ ഒരു നല്ല കുടുംബിനിയായാവാൻ കഴിയുകയില്ലെന്നാണ് അയാൾ ചിന്തിക്കുന്നത്. സ്ത്രീകളെ ജോലിക്ക് വിടാതെ വീടിന്റെ അടുക്കളയിൽ തളച്ചിടുന്ന പുരുഷ സമൂഹത്തിന്റെ മേൽക്കോയ്മയെ ചോദ്യം ചെയ്യുകയായിരുന്നു. കഥാനായികയുടെ അഭിപ്രായ പ്രസനത്തിലൂടെ. സ്വന്തം ഇഷ്ടങ്ങൾ അടിച്ചമർത്തപ്പെടും എന്ന മുൻധാരണയിൽ മോഹൻ എന്ന കാമുകനെ കഥാനായിക ബോധപൂർവ്വം ഒഴിവാക്കുന്നു. എന്നിരുന്നാൽക്കൂടിയും മോഹന്റെ അപ്രതീക്ഷിതമരണം അവളെ നിരന്തരം പിന്തുടരുന്നു.

യാന്ത്രികമായി പണികൾ ചെയ്യുന്ന കഥാനായികയെയാണ് പിന്നീട് കഥാകാരി അവതരിപ്പിക്കുന്നത്. ഭാര്യയുടെ കൂട്ടുകാരി ഫോൺ : ചെയ്തതു മൂലം അവൾക്ക് തലവേദയാണെന്നറിഞ്ഞ ഭർത്താവ് ഇന്നു കൂടി ഓഫീസിൽ നിന്ന് അവധിയെടുത്ത് വിശ്രമിക്കാൻ കഥാനായികയോടു പറഞ്ഞു. വീട്ടിലെ സ്ത്രീകളുടെ പരിമിതികളോ, അവരുടെ അസ്വസ്ഥതകളോ, കഷ്ടപ്പാടുകളോ അറിഞ്ഞ് പെരുമാറാൻ പുരുഷസമൂഹം തയ്യാറാകുന്നില്ല. വീട്ടിലെ സ്ത്രീകൾക്ക് ഒരു ദിവസം പനിയോ മറ്റോ വന്നാൽപ്പോലും അവളെ ഒന്ന് ശ്രദ്ധിക്കാൻ പോലും ആരും കാണില്ല. ആസ്പിരിൻ ഗുളികകളോ മറ്റ് വേദനാ സംഹാരികളോ ഒക്കെ ആവും രോഗദശയിലെ സ്ത്രീകളുടെ കൂട്ടുകാർ.

പതിവുപോലെ തന്നെ ഭർത്താവും കുട്ടികളും പോയപ്പോൾ അവൾവീട്ടിൽ തനിച്ചായി. എന്തോ തീരുമാനിച്ചുറപ്പിച്ച മട്ടിൽ അവൾ തന്റെ അടുത്ത സുഹൃത്തായ ആഷയെ ഫോണിൽ വിളിച്ച് തനിക്ക് മോഹന്റെ വീട്ടിൽ പോകണമെന്ന ആവശ്യം അറിയിക്കുന്നു. ഒരു കാരണവുമില്ലാതെ അങ്ങോട്ട് എങ്ങനെ കയറി ചെല്ലും എന്ന് ആഷ നിരീത്സാഹപ്പെടുത്തുന്നുണ്ടെങ്കിലും കഥാനായിക അതൊന്നും ചെവികൊള്ളാതെ തന്റെ ആവശ്യം ഒന്നുകൂടി ഉറപ്പിച്ചുറപ്പിക്കുന്നു. ആഷയോട് കാറിൽ ഇരുവരും മോഹന്റെ വീട്ടിൽ പോകുമ്പോഴും കഥാനായികയുടെ ഓരോ കിറുകകളെപ്പറ്റി ആഷ അസ്വാഭാവികതയോടെ പറയുന്നു. മോഹന്റെ യുംസുഹൃത്തായ ആഷയോട് അയാൾ തന്നെ വിവാഹം കഴിക്കാത്തതിൽ മോഹൻ വിഷമം ഉായിരുന്നോ എന്ന് അവൾ ചോദിക്കുന്നു. മോഹന്റെ വീടിന് മുന്നിൽ നിന്ന് കോളിംഗ്ബെൽ അടിച്ചപ്പോൾ അയാളുടെ ഭാര്യ ഇറങ്ങിവരുകയും ആരെ കാണാനാണെന്ന് ചോദിക്കുകയും ചെയ്യുന്നു. ആരെ കാണാനാണ് എന്ന് കഥാനായികയുടെ മനസ്സും അവളോട് മന്ത്രിച്ചുകൊണ്ടിരുന്നു. ഞങ്ങൾക്ക് വീട് തെറ്റിയതാണെന്ന് പറഞ്ഞ് ദുഃഖമായ ചുവടുകളോടെ മോഹന്റെ വീട്ടിൽ നിന്നും കഥാനായിക ഇറങ്ങുന്നു. ഇക്കഥയുടെ അവസാനം ഇപ്രകാരമല്ലായിരുന്നു താൻ സങ്കല്പിച്ചിരുന്നതെന്ന് കഥാകാരിതന്നെ തുറന്ന് പറയുന്നു. ആഷയുടെ വാക്കുകൾ കടമെടുത്താൽ 'ഇറ്റീസ് ടുലേറ്റ്'

സ്ത്രീകൾക്ക് വേറി വാദിക്കുന്ന പ്രതിനിധികളിലൊരാളാണ് ടുലേറ്റിലെ നായിക. കാമുകനുമായി പ്രണയലീലകളിൽ മുഴുകി മൃഗശാലയിലും മറ്റും പോകാനുണ്ടെങ്കിലും തന്റെ വ്യക്തിത്വം ആർക്കുമു ന്നിലും പണയം വയ്ക്കാൻ കഥാനായിക തയ്യാറാവുന്നില്ല. ഒരു സ്ത്രീയുടെ ഏറ്റവും വലിയ റോൾ അമ്മ യുടെതാണെന്നും സ്ത്രീകൾക്ക് ജോലിയുടെ ആവശ്യമില്ലെന്നും പറയുന്ന മോഹനനോട് തങ്ങൾക്കും അഭിമാനവും അന്തസ്സുമുണ്ട് ബോധ്യം ഉളവാക്കുന്ന തരത്തിലുള്ള അഭിപ്രായപ്രകടനങ്ങൾ അവർ നടത്തുന്നു. സ്ത്രീകളെ സമൂഹത്തിന്റെ അടിത്തട്ടിലേക്ക് ചവിട്ടിതാഴ്ത്തുന്ന പുരുഷമേൽക്കോയ്മക്കെതി രെയുള്ളതായിരുന്നു അവ. തന്റെ ഇഷ്ടങ്ങൾ ചോദിച്ചു വാങ്ങാനായി കാമുകന്റെ മുഖം മറന്ന് മറ്റൊരാളെ കല്യാണം കഴിക്കുന്നതും അവളുടെ സ്വാതന്ത്ര്യാഭിലാഷത്തിന്റെ ശ്രമങ്ങളായിട്ടുവേണം കണക്കാക്കാൻ 'ടുലേറ്റ്' എന്ന കഥയുടെ ആദിമധ്യാന്തം സ്ത്രീകൾക്കെതിരെയുള്ള ചൂഷണത്തിൽ നിന്നും അവരെ മോചി പ്പിക്കാൻ പ്രാപ്തമാക്കുന്ന കഥാകാരിയുടെ ശബ്ദമാണ് നാം കേൾക്കുന്നത്. അനുവാചകർക്ക് മുന്നിൽ കഥാനായികയുടെ ജീവിതത്തിലൂടെ അതിന് കൂടുതൽ തെളിവേകി. കഥാഗതികളിൽ ചിലതൊഴിച്ചു നിർത്തി യാൽ ടുലേറ്റ് എന്ന് കഥ തികച്ചും, സ്ത്രീവാദം ഉൾക്കൊള്ളുന്ന കൃതിയാണെന്ന് നിസ്സംശയം പറയാ നാകും

സ്ത്രീവാദത്തിന്റെ സ്വാധീനം കവിതയുടെ കഥയിൽ

പെൺമനസിലെ സകല ചൈതന്യവും കോർത്തിണക്കിയതാണ് ചന്ദ്രമതിയുടെ കഥകൾ. വ്യത്യ സ്ഥമായ ആഖ്യാന ശൈലികളും പരീക്ഷണ ശില്പങ്ങളുമാണ് അതിൽ നിഴലിക്കുന്നത്. പുരുഷ മേൽക്കോയ്മയെ ചിത്രീകരിക്കുന്നതിന് ക്രൂരമായ നർമ്മചിത്രീകരണങ്ങളും കഥകളിൽ കടന്നു വരാറു ു. സുഷമ്മ എന്ന ഒരുസാധാരണ കുടുംബിനിയുടെ ചിത്രീകരണമാണ് കവിതയുടെ കഥയിലൂടെ ചന്ദ്ര മതി വരച്ചുകാട്ടുന്നത്. സർഗ്ഗാത്മക രചനകളിൽ കഴിവുവായിട്ടും അവയൊന്നും പുറംലോകം കാണാതെ മുടിവെയ്ക്കുന്ന ഒട്ടനവധി സ്ത്രീ എഴുത്തുകാരുടെ പ്രതിനിധിയാണ് സുഷമ്മ എന്ന് നിസ്സം ശയം പറയാനാകും. ഭർത്താവ് ഏതെങ്കിലും മണ്ഡലത്തിൽ ഔന്നത്യം നേടുന്നത് ഭാര്യ അഭിമാനമായി കരുതുന്നു. എന്നാൽ അതിനേക്കാളേറെ സ്വയം ഔന്നത്യം നേടാൻ അവൾക്ക് ഭയമാണ്. അത് ഭർത്താ വിന് രസിച്ചില്ലെന്നുവരാം ഈയൊരവസ്ഥയാണ് കഥാനായികയായ സുഷമ്മയുടെയും.

കുറിപ്പുകൾ

1. ചന്ദ്രമതി, ചന്ദ്രമതിയുടെ കഥകൾ പുറം 109, സങ്കീർത്തനം പബ്ലിക്കേഷൻസ്, കൊല്ലം, മാർച്ച് 2002
2. ചന്ദ്രമതി, ചന്ദ്രമതിയുടെ കഥകൾ പുറം 109
3. ചന്ദ്രമതി, ചന്ദ്രമതിയുടെ കഥകൾ പുറം 465, ഡി.സി. ബുക്സ്, കോട്ടയം, ഒക്ടോബർ 2009

ഗ്രന്ഥസൂചി

1. ഗീത ആധുനികമലയാള കവിതയിലെ സ്ത്രീപക്ഷ സമീപനങ്ങൾ
ലിപി പബ്ലിക്കേഷൻസ്, കോഴിക്കോട്, സെപ്റ്റംബർ 2002.
2. ചന്ദ്രമതി, ഇവിടെയൊരു ടെക്കി, ഡി.സി. ബുക്സ്, കോട്ടയം, നവംബർ 2010
3. ചന്ദ്രമതി, രത്നാകരന്റെ ഭാര്യ, ഡി.സി. ബുക്സ്, കോട്ടയം, നവംബർ 2012
4. ജയകൃഷ്ണൻ.എൻ (എ ഡി), പെണ്ണെഴുത്ത്, കേരള ഭാഷ ഇൻസ്റ്റിറ്റ്യൂട്ട്
തിരുവനന്തപുരം, ജൂൺ 2011
5. ജാൻസി ജെയിംസ് (ഡോ) (എ ഡി), ഫെമിനിസം 1, കേരള ഭാഷാ ഇൻസ്റ്റിറ്റ്യൂട്ട്
തിരുവനന്തപുരം, മാർച്ച് 2000
6. ബഷീർ കഥാസാഹിത്യ ചരിത്രം കേരള സാഹിത്യ അക്കാദമി, തൃശ്ശൂർ, മെയ് 2002

कबीर के मानवीय मूल्यों की पुनर्चना और हिन्दी नाटक

सारांश

कबीरदास देश काल की सीमाओं से मुक्त एक अद्वितीय व्यक्तित्व हैं। कवि, दार्शनिक और सुधारक तीनों प्रतिभा उनमें समान रूप में आकर मिल गई है। उन्होंने अपनी कविता के माध्यम से मध्यकालीन मानव विरोधी कार्यों का विरोध किया। कबीर की प्रतिबद्धता आधुनिक रचनाकारों के लिए प्रेरणादायक रही है। हिन्दी साहित्य की विभिन्न विधाओं में या तो कबीर को पात्र बनाकर या कबीर के विचारों को अपनाकर रचना की जा रही है। इस प्रकार कई नाटक, उपन्यास, कहानी, कविताएँ, निबन्ध और आलोचनात्मक ग्रन्थ आदि लिखे गये हैं। समकालीन परिवेश की विकृतियों को व्यक्त करके, उनके खिलाफ विरोध प्रकट करने के लिए रचनाकारों ने अपनी रचनाधर्मिता में कबीर के मूल्यों को सुरक्षित रखने का प्रयास किया है। प्रस्तुत आलेख में कबीर को पात्र बनाकर रचित हिन्दी नाटकों के संदर्भ में कबीर के मानवीय मूल्यों की पुनर्चना पर विचार किया गया है।

कबीर ने अपने समय में मानवीय मूल्यों के प्रवक्ता रचनाकार की भूमिका निभायी थी। उन्होंने समाज के यथार्थ को पहचानकर अपनी रचनाधर्मिता को निभाया था। हर काल में ऐसे रचनाकारों की ज़रूरत होती है जो समाज की वास्तविकता को पहचानते हो। उन्होंने समाज में मनुष्य की पहले से बनाई गई पहचान को अस्वीकार किया। जाति और धर्म के आधार पर बनाई गई सभी शर्तों को तोड़ने का प्रयास किया। उन्हें सिर्फ मानवीयता पर विश्वास था। इसलिए उनके सभी विचारों का आधार ही मानवीयता है। मैनेजर पाण्डेय लिखते हैं, “ कबीर समाज में मनुष्यत्व के विकास के लिए हृदय के धर्म अर्थात् मानवीय भावों को लोकधर्म बनाने पर जोर देते हैं, इसलिए वे एक ओर ईर्ष्या, क्रूरता, कामुकता, कपट, अहंकार आदि की आलोचना करते हैं, तो दूसरी ओर प्रेम, करुणा, दया, उदारता, अहिंसा और समता का विकास चाहते हैं।” कबीर के विचार में इन्हीं मानवीय भावों के प्रचार और अनुसरण से ही समाज में शांति कायम कर सकते हैं। वर्तमान समय के प्रगतिशील रचनाकार कबीर के इन्हीं विचारों से समकालीन चुनौतियों का सामना करने की ऊर्जा प्राप्त करते हैं। समकालीन रचनाकार कबीर के विचारों को आत्मसात कर सर्जनात्मकता में जुड़े रहते ही नहीं, बल्कि कबीर को ही अपनी रचनाओं का नायकत्व प्रदान करते हैं। सामाजिक, राजनीतिक एवं धार्मिक समस्याओं के सामने वे कबीरदास को प्रतिपक्षधर्मी पात्र के रूप में खड़ा कर देते हैं। इस प्रकार कबीर को केन्द्र पात्र बनाकर रचित रचनाओं में वर्तमान संदर्भ में कबीर की मानवीयता को पुनः सृजित करने का प्रयास किया गया है।

कबीर को केन्द्र बनाकर आधुनिक हिन्दी साहित्य में मुख्यतः पाँच नाटक लिखे गये हैं। मणिमधुकर का ‘इकतारे की आंख’, भीष्म साहनी का ‘कबिरा खड़ा बज़ार में’, नरेन्द्र मोहन का ‘कहै कबीर सुनो भाई साधो’, महावीर अग्रवाल का ‘काशी का जुलाहा’ और सुमान कुमार का ‘गगन घटा घहरानी’। इन नाटकों में नाटककारों ने कबीर के द्वारा वर्तमान के मानवविरोधी प्रवृत्तियों के विरुद्ध अपनी असहमति प्रकट की है। आज समाज में मानव-मानव के बीच भेद-भाव की अनेक दीवारों खड़ी हो गयी हैं। रचनाकार कबीर के मूल्यों को अपनाकर इन दीवारों को

Dr. Uma. T.M

Contract Lecturer

Department of Hindi

Sree Sankaracharya University of

Sanskrit, Kalady

Regional Centre, Thrissur.

तोड़ने में कार्यरत हैं। 'कबिरा खड़ा बज़ार में' नाटक में नाटककार भीष्म साहनी कबीर के द्वारा यह कहते हैं कि " मैं इन्सान को हिन्दू और तुर्क की नज़र से नहीं देखता, मैं उसे केवल इन्सान की नज़र से, खुदा के बन्दे की नज़र से देखता हूँ।" कबीर के अनुसार जन्म से सभी इन्सान होते हैं। लेकिन सामाजिक परिवेश उन्हें हिन्दू और मुसलमान बनाकर अलग कर देता है। इसलिए उन्होंने मनुष्य के बीच अलगाव पैदा करनेवाली शोषक शक्तियों का विरोध किया। यहाँ नाटककार का भी मुख्य ध्येय मनुष्य को आपस में जोड़ना है। क्योंकि धार्मिक विद्वेष के कारण हिंसा का ताण्डव होने वाला एक समाज नाटककारों के सामने मौजूद है। ऐसी परिस्थिति में मानवीयता की पुनःस्थापना के लिए नाटककारों को कबीर के मूल्य प्रेरणा देते हैं।

मानवीयता को बनाये रखने के लिए संघर्षरत कबीर के व्यक्तित्व को, छह सौ साल बाद, आज के संदर्भ में प्रस्तुत करने का कार्य नाटककार नरेन्द्र मोहन ने भी किया है। 'कहै कबीर सुनो भाई साधो' नाटक में गायक के शब्दों के द्वारा नाटककार कबीर की प्रासंगिकता को व्यक्त करते हैं। " मैं तुम्हें, शूरवीर की विशेषता बता रहा हूँ। तुम्हें लड़ना सिखा रहा हूँ। अंधी लड़ाई नहीं मन की आँखें खोलकर लड़ने की कला। आओ, तुम्हें ले चलूँ ६०० वर्ष पूर्व, काशी की जुलाह पट्टी में।" यहाँ आँखें खोलकर लड़ने की कला से नाटककार का तात्पर्य है मनुष्य जो उसके संपूर्ण परिवेश के साथ एक सच्ची आलोचनात्मक दृष्टि से देखना और परिवेश की आवश्यकता के अनुसार संघर्ष करना। कबीर ने ऐसा ही किया था। यहाँ नाटककार रचनाकार को संघर्षशील बनने की आवश्यकता पर जोर देते हैं। क्यों कि समाज में शोषक शक्तियाँ मिलजुलकर दानवी कार्यों में संलग्न हैं। ये मनुष्य के बीच दूरियाँ बढ़ाकर स्वयं लाभान्वित होते रहते हैं। समाज की यह विषाक्तता प्रगतिशील रचनाकार को लड़ने के लिए मजबूर कर रही है और कबीर का व्यक्तित्व इसके लिए साहस जुड़ाने की प्रेरणा भी दे रहा है। यहाँ नाटककार निडर होकर शोषण शक्तियों के खिलाफ लड़ने का आह्वान दे रहे हैं।

सत्ता द्वारा आर्थिक शोषण का व्यापक चित्र कबीर केन्द्रित रचनाओं में प्रस्तुत है। आज श्रमजीवी मनुष्य भी आर्थिक शोषण की वजह से दयनीय अवस्था में पहुँच गया है। इसके बारे में मणिमधुकर के नाटक 'इकतारे की आंख' में चित्रण है। नाटक में सरकारी फीलखाने के हाथियों को खिलाने-पिलाने की जिम्मेदारी साधारण लोगों को दी जाती है। ये लोग बहुत गरीब थे। हाथी को खिलाते-खिलाते उनके काम धंधे चौपट हो जाते हैं। इससे छुटकारा पाने के लिए शिकायत लेकर कोतवाल के पास पहुँच जाता है तो स्थिति और भी बिगड़ जाती है। शिकायत लेकर कोतवाल के पास आये व्यक्ति को कोतवाल सजा सुनाता है क्योंकि उनकी शिकायत

से बगावत की बू आ रही थी। सिपाही के शब्दों में " .. आज से तुम्हारे मुहल्ले पर दो हाथियों की देख-भाल का जिम्मा और। लगाओ इसके पचास कोड़े।" इस प्रकार आर्थिक शोषण के विरुद्ध आवाज़ उठाने पर सत्ताधारी वर्ग उसका दमन करता है। यह वर्ग हाथियों के पालन के अतिरिक्त पंडितों, मुल्लाओं, महंतों और जोगियों के खान-पान भोग-आराम आदि की जिम्मेदारी भी अलग-अलग मुहल्लों पर डाल देता है। यहाँ नाटककार यह कहना चाहते हैं कि हर युग और काल का शोषक वर्ग जन सामान्य के शोषण में कोई कसर नहीं छोड़ता है। आज भी जनता की मेहनत के शोषण में राजनीतिज्ञ के साथ पंडित, मुल्ला-पातिरी भी एक साथ खड़े दिखाई देते हैं।

कबीर जनसामान्य की निर्धनता को अच्छी तरह पहचानते थे। वे स्वयं निम्न तथा अभावग्रस्त थे इसलिए सामंती समाज व्यवस्था के शोषणकारी शिकंजे से जनता को मुक्ति दिलाना चाहते थे। लेकिन आमजनता को न्याय दिलाने के लिए कोई भी व्यवस्था नहीं थी। उलटे शासक वर्ग, कोई न कोई बहाना बनाकर लोगों को सताता और धमकाता रहता था। ऐसी व्यवस्था के बारे में 'कहै कबीर सुनो भाई साधो', नाटक में कबीर का कथन है, "यह तो चोरों और डाकुओं का राज हुआ यह तो अन्याय है, ..." यहाँ कबीर के इस कथन के माध्यम से नाटककार वर्तमान क्रूर व्यवस्था पर चोट करते हैं। ऐसी शासन व्यवस्था का पर्दाफाश भीष्म साहनी भी अपने नाटक में करते हैं। कबीर खड़ा बज़ार में नाटक में कबीर सुल्तान सिकन्दर लोदी से कहते हैं, " किसी के आँसु दूसरे के लिए मोती जुटा देते हैं और उसे अपने लिए चिथड़े भी नहीं जुड़ा पाते।" नाटककार यहाँ कबीर के जैसे निडर होकर, यह घोषित करते हैं कि जनतंत्र के शासक डाकुओं और लुटेरों से भी बदतर हैं।

निर्भय होकर यथार्थ को उद्घाटित करने की क्षमता कबीर की वाणी में थी। समकालिक रचनाकार भी अपनी रचनाओं में उसी निर्भयत्व को समेटना चाहते हैं। ये रचनाकार मानवविरोधी कार्यवाहियों को देखकर चुप रहने के लिए तैयार नहीं हैं बल्कि उनके विरुद्ध पूरे साहस के साथ विरोध करने का प्रयास करते हैं। 'इकतारे की आंख' में नाटककार मणिमधुकर का प्रतिरोधी स्वर मुखरित है। नाटक में गायक की पंक्तियाँ हैं-की पंक्तियाँ हैं-

"गलत को गलत कहो

गलत का विरोध करो

जांत-पांत तोड़कर छेड़ो सब एक तान

मानुष मानुष एक समान"

इन पंक्तियों में समता पर आधारित एक समाज के लिए संघर्ष करने की प्रेरणा है। यहाँ नाटककार की प्रतिबद्धता और मनुष्य की

पक्षधरता दिखाई देती हैं। यह पक्षधरता कबीर की वाणी की सबसे बड़ी विशेषता है। इससे गलत कार्यों के विरुद्ध लड़ने की ताकत मिल जाती है।

कबीर केन्द्रित रचनाओं में पारिवारिक मूल्यों की अहमियत को भी प्रस्तुत किया गया है। क्योंकि कबीर ने पारिवारिक मूल्यों को बहुत अधिक माना है। उन्होंने घर का महत्व पहचान लिया था। नरेन्द्र मोहन के शब्दों में “कबीर की वाणी और ज़िन्दगी के अंतर्सम्बन्धों को देखें तो पाएंगे कि उनकी ज़िन्दगी की गाठें वाणी में खुली हैं और वाणी उनकी ज़िन्दगी की खुली किताब है। आप जानते हैं कि घर उनकी साखियों में बार-बार आया है। वे घर में घर दूढ़ते भी दिखते हैं। बेघर होते जा रहे आज के आदमी के लिए कबीर का घर कम आकर्षक नहीं है।” आज मूल्य संक्रमण की स्थिति ने पारिवारिक सम्बन्धों को बुरी तरह से हिलाया है। इस संदर्भ में रचनाकारों ने पारिवारिक मूल्यों को ऊपर उठाने का प्रयास किया है। ‘कबिरा खड़ा बज़ार में’ नाटक में कबीर और उनकी माँ के प्रसंगों में ममता और वात्सल्य भाव को प्रस्तुत किया गया है, जो माँ और बेटे के रिश्ते को मज़बूत करने की कड़ी है। कबीर अपनी माँ के बारे में कहते हैं “जब कोई आँधी चलती है तो अपनी दुबली सी काया से मुझे अपने ओट में ले लेती है, कि आँधी-बवण्डर के थपेड़े उस पर न पड़े, कबीरा बच जाये। (हँसकर) इतनी छोटी सी तो है, यह मेरी माई। फिर भी समझती है सभी मुसीबतों से मुझे बचा लेगी। माई के दिल में जैसे कोई बाती जलती रहती है प्रेम की बाती। उसी की लौ में वह सारा वक्त जीती है” यहाँ कबीर के मन में माँ की प्रति जो संवेदना है, नाटककार ने उसे दिखाकर वर्तमान

समाज से नष्ट होते जा रहे पारिवारिक मूल्यों को जगाने का प्रयास किया है। इसके अलावा कबीर और लोई की बीच के आपसी प्रेम और विश्वास को दिखाकर यह साबित करने का प्रयत्न किया है कि प्रेम और विश्वास ही परिवार की नींव है। आज यह नींव हिलती दिखाई दे रही है। ऐसे में रचनाकार वह दायित्व निभाने का प्रयत्न कर रहे हैं कि अपनी रचनाओं के माध्यम से पारिवारिक मूल्यों की पुनः स्थापना हो जाये। कबीर केन्द्रित रचनाओं में इस दायित्व का निर्वाह करने का प्रयास रचनाकारों ने किया है।

समाज से नष्ट होते जा रहे पारिवारिक मूल्यों को जगाने का प्रयास किया है। इसके अलावा कबीर और लोई की बीच के आपसी प्रेम और विश्वास को दिखाकर यह साबित करने का प्रयत्न किया है कि प्रेम और विश्वास ही परिवार की नींव है। आज यह नींव हिलती दिखाई दे रही है। ऐसे में रचनाकार वह दायित्व निभाने का प्रयत्न कर रहे हैं कि अपनी रचनाओं के माध्यम से पारिवारिक मूल्यों की पुनः स्थापना हो जाये। कबीर केन्द्रित रचनाओं में इस दायित्व का निर्वाह करने का प्रयास रचनाकारों ने किया है।

कबीर पारिवारिक मूल्यों को अहमियत देने के साथ-साथ श्रम की महत्ता को भी बहुत मानते थे। संत होकर भी उन्होंने कभी भी लोगों के सामने हाथ नहीं पसारा। वे कपड़ा बुनाकर ही अपनी जीविका चलाते थे। उनके अनुसार हर आदमी को रोटी खुद कमाकर खाना चाहिए। उन्होंने मेहनत में भी ईश्वर का रूप देखा है। ‘कबीरा खड़ा बज़ार में’ नाटक में कबीर इसके बारे में कहते हैं, “मेरी फकीरी के लिए घर-बाहर छोड़ने की ज़रूरत नहीं है। मेरी नज़र में हर काम इबादत है। इसका मतलब यह है कि मनुष्य की अच्छाई के लिए करने वाले हर काम इबादत है।” इससे ईश्वर की प्राप्ति होती है। वर्तमान समय में तो शारीरिक श्रम को हीन भावना से लोग देखते हैं। मनुष्य के श्रम और उत्पादन में उसका कोई नियंत्रण भी नहीं रहा। व्यवसायीकरण के इस समय में वस्तुएँ मनुष्य से भी शक्तिशाली बनती जा रही हैं। यहाँ मनुष्य और उसका श्रम नगण्य हो जाता है। इस संदर्भ में हमें कबीर के मूल्यों से बहुत कुछ सीखना बाकी है। शारीरिक मेहनत को हीन समझ कर परायों के दफ्तर में काम दूँढ़ने वाली नयी पीढ़ी के सामने कबीर का शारीरिक श्रम भी एक मूल्य होकर उपस्थित होता है।

कबीर केन्द्रित रचनाओं में कबीर के प्रतिपक्ष धर्मों मूल्यों को बहुत अधिक सराहा गया है। प्रतिपक्ष में खड़ा रहने के कारण कबीर की वाणी में सत्ता विरोधी स्वर बहुत ही प्रखर दिखाई देता है। ‘कहै कबीर सुनो भाई साधो’ नाटक में कबीर के इस प्रतिरोधी स्वर को इस प्रकार व्यक्त किया गया है कि-

“एक दहकता शब्द
जलाकर राख बना देता है
पूरी पशु सत्ता को
एक दहकता शब्द
हिलाकर रख देता है
सन्नाटे की बड़ी बड़ी चट्टानों को”
हिलाकर रख देता है
सन्नाटे की बड़ी बड़ी चट्टानों को”

इन पंक्तियों में कबीर की वाणी का प्रतिरोधी एवं आक्रामक स्वभाव व्यक्त हो जाता है। कबीर की वाणी में सत्ता केन्द्रों को हिलाने की अद्भुत क्षमता है। नाटककार ने उस क्षमता को पहचाना है और इसलिए उन्होंने ऐसे दहकते शब्द को अभिव्यक्त करके वर्तमान के सत्ता केन्द्रों को हिलाने की कोशिश की है। सुमन कुमार का नाटक “गगन घटा घहरानी” में इस व्यवस्था विरोधी भावना को बहुत अधिक सराहा है। नाटक में कबीर की पंक्तियाँ हैं-

“सुलतान , बादशाह, नेता, प्रधानमंत्री, सन्तरी

करते उपेक्षा जन की

लगा है तुम्हारा दरबार षड्यन्त्र का

भोगविलास का अड़्डा”

सत्ता के दमन और उपेक्षा के विरुद्ध संघर्षरत कबीर को प्रस्तुत करके रचनाकारों ने अपनी सत्ता विरोधी मानसिकता को प्रकट किया है। कबीर के निडर व्यक्तित्व से रचनाकार बहुत अधिक प्रभावित हैं। इसका प्रतिफलन कबीर केन्द्रित रचनाओं में साफ दिखाई देता है। इन रचनाओं का मुख्य ध्येय मनुष्य की चेतना को जगाकर उसे अमानवीय व्यवस्था विरोध में खड़ा करना है। रचनाकारों ने कबीर जैसे प्रतिरोधी व्यक्तित्व को अपनी रचनाओं का केन्द्र बनाया है क्योंकि कबीर के राजनैतिक मूल्यों के केन्द्र में मनुष्य को समानता देनेवाली शासन व्यवस्था की परिकल्पना है। कबीर के इन राजनैतिक मूल्यों का आधार बनाकर रचनाकारों ने अपनी रचनाओं में व्यवस्था विरोधी चेतना की प्रस्तुति द्वारा एक शोषण मुक्त समाज की कल्पना की है।

कबीर केन्द्रित रचनाओं में समकालीन दौर के धर्म की अमानवीय प्रवृत्तियों पर प्रकाश डालने का प्रयास भी किया गया है। धार्मिक मूल्यों के हास के इस युग में कबीर के धार्मिक मूल्यों को अपनी रचनाओं में अभिव्यक्त करके रचनाकारों ने धर्म के मानवीय पक्ष पर जोर दिया है। मध्यकालीन समय के समान आज भी आज भी धर्म मनुष्य के बीच अलगाव पैदा कर रहा है। वर्तमान समाज में धर्म साम्प्रदायिकता को प्रश्रय दे रहा है। इससे मनुष्य-मनुष्य के बीच गहरी खाई पैदा हो रही है। इसके बारे में भीष्म साहनी [कबीरा खड़ा बज़ार में] नाटक में कबीर के माध्यम से कहते हैं, “कोई ऐसा धर्माचार नहीं जो इन्सान को इन्सान के साथ जोड़े, सभी इन्सान को इन्सान से अलग करते हैं। एक दूसरे के दुश्मन बनाते हैं।” वर्तमान की धार्मिक असहिष्णुता के प्रतिरोध के रूप में रचनाकारों ने कबीर के धार्मिक मूल्यों को प्रस्तुत किया है। कबीर के लिए धर्म की नींव ही इन्सान की सेवा है। जब धर्म में इस सेवा भाव का लोप होता है तब कबीर उस धर्म के प्रति आक्रामक रवैया अपनाते हैं।

धर्म मनुष्य के बीच अलगाव पैदा कर रहा है। वर्तमान समाज में धर्म साम्प्रदायिकता को प्रश्रय दे रहा है। इससे मनुष्य-मनुष्य के बीच गहरी खाई पैदा हो रही है। इसके बारे में भीष्म साहनी ‘ कबीरा खड़ा बज़ार में ’ नाटक में कबीर के माध्यम से कहते हैं, “कोई ऐसा धर्माचार नहीं जो इन्सान को इन्सान के साथ जोड़े, सभी इन्सान को इन्सान से अलग करते हैं। एक दूसरे के दुश्मन बनाते हैं।” वर्तमान की धार्मिक असहिष्णुता के प्रतिरोध के रूप में रचनाकारों ने कबीर के धार्मिक मूल्यों को प्रस्तुत किया है। कबीर के लिए धर्म की नींव ही इन्सान की सेवा है। जब धर्म में इस सेवा भाव का लोप होता है तब कबीर उस धर्म के प्रति आक्रामक रवैया अपनाते हैं।

धर्म में मानवीय तत्वों की खोज के लिए रचनाकारों ने कबीर के धार्मिक मूल्यों को अपनाया है। ‘ कहे कबीर सुनो भाई साधो ’ नाटक में कबीर अपने ईश्वरीय विचारों को व्यक्त करते हुए कहते हैं, “ मेरा कोई मज़हब नहीं, मेरा किसी मज़हब से विरोध नहीं, मेरे लिए राम-रहीम समान है। हिन्दु-मुसलमान दो नहीं, एक ही ईश्वर के बंदे हैं।” यह कथन इस बात की गवाही दे रहा है कि कबीर मज़हब विरोधी नहीं थे। उन्होंने सभी धर्मों के मानवीय मूल्यों को हमेशा सराहा है। लेकिन ये मूल्य धर्म के व्यावहारिक नीतियों में न के बराबर थे। आज भी स्थिति भिन्न नहीं है। इसलिए इस धार्मिक अवमूल्यन के विरुद्ध आवाज़ उठाने के लिए रचनाकारों ने कबीर को एक माध्यम बनाया है। रचनाकारों ने समाज में प्रचलित धार्मिक शोषण और अनाचारों के विरुद्ध सशक्त भाषा में प्रतिरोध खड़ा कर दिया है और साथ ही कबीर के मूल्यों के ज़रिए इन्सानियत को प्रोत्साहन भी दिया है। ‘ कबीरा खड़ा बज़ार में ’ नाटक में कबीर का कथन है, “ मेरा परवरदिगार मेरे चारों ओर है, वह मेरे दिल में बसता है। उसकी नज़र में न कोई हिन्दू है, न तुर्क। मैं अल्लाह का नूर हर इन्सान में देखता हूँ, इन्सान के दिल में देखता हूँ। “कबीर ने हमेशा अपनी वाणी के द्वारा मनुष्य के भीतर समायी हुई ईश्वरीय शक्ति से लोगों का परिचय कराना चाहा। नाटककार यह पहचानते हैं कि धर्म और ईश्वर के बारे में कबीर की यह परिकल्पना, वर्तमान के कलुषित धार्मिक परिवेश में बहुत ही उपयोगी है। वर्तमान समय में धर्म और सम्प्रदाय के नाम पर लोगों के बीच अनेक दीवारें खड़ी हैं। इन दीवारों के पीछे राजनैतिक आकांक्षाएँ और स्वार्थता काम कर रही हैं। मानव धर्म की जड़ें मज़बूत करने के लिए इन दीवारों को गिराना बहुत ज़रूरी है। कबीर केन्द्रित रचनाओं में रचनाकारों ने कबीर के मूल्यों को प्रस्तुत करके इन दीवारों पर प्रहार करने का प्रयत्न किया है। रचनाकारों के इस प्रयत्न में कबीर के मानव धर्म की परिकल्पना बहुत अधिक उम्मीदें जगाती है। इस वजह से इन रचनाकारों की रचनाओं में कबीर की वाणी दुहराती रहती है। कबीर की वाणी दुहराती रहती है।

कबीर केन्द्रित रचनाओं में रचनाकारों ने कबीर के आध्यात्मिक मूल्यों के द्वारा वर्तमान समय के धर्म की मानव विरोधी चेष्टाओं और आध्यात्मिक व्यवसाय पर प्रश्न चिह्न लगा दिया है। कबीर का धर्मतर अध्यात्म मानव प्रेम का पर्यायवाची है। उन्होंने पण्डितकाल की धार्मिक असहिष्णुता के विरुद्ध एक प्रतिरोध के रूप में इस धर्मतर अध्यात्म की परिकल्पना की थी। इसके बारे में सुमन कुमार का ‘गगन घटा घहरानी’ शीर्षक नाटक में कथागायक की पंक्तियाँ-

“निराशा-उदासी डर-खौफ

में डूबा यह आदमी
 उसे चाहिए
 आशा, प्रेम, सद्भावना
 एक ब्रह्मा, खुदा, ईश्वर, गॉड कुछ भी
 'राम'
 शून्यमण्डल, निराकार
 जिसमें सब समाहित होकर बनेंगे
 एक शक्ति पूंज
 निर्गुण
 फिर साथ-साथ चलेंगे ”

कबीर केन्द्रित रचनाओं में भी कबीर का अध्यात्म एक प्रतिरोध है, जो वर्तमान धार्मिक तथा आध्यात्मिक शोषण के विरुद्ध सशक्त रूप में आक्रमण करता है। रचनाकारों ने उस धर्मोत्तर अध्यात्म के माध्यम से समदृष्टि की भावना का प्रचार करने का प्रयास किया है। कबीर के लिए समदृष्टि एक ऐसा मूल्य है, जिसका प्रचार उनकी वाणी का मुख्य ध्येय है। कबीर का यह मूल्य वर्तमान समय में भी उतना ही महत्वपूर्ण है। इसलिए समकालीन रचनाकार भी उसका प्रचार चाहते हैं।

निष्कर्षतः, कबीर केन्द्रित रचनाओं में कबीर के मानवीय मूल्यों की प्रस्तुति, वर्तमान समय की चुनौतियों के उत्तर ढूँढने के लिए एक दिशा निर्देश के रूप में की गयी है। इन रचनाओं में रचनाकारों ने कबीर के मूल्यों पर बल देकर, शोषण मुक्त समाज के लिए लोगों को संघर्षरत रहने का आह्वान दिया है। यह कार्य कबीर केन्द्रित नाटकों में बखूबी ढंग से किया गया है। नाटकों में मानवीय मूल्यों की स्थापना के लिए कबीर का संघर्ष और शोषक शक्तियों के विरुद्ध उसका आक्रामक तेवर बहुत ही अनोखे ढंग से, वर्तमान के साथ जोड़कर पुनर्चित किया गया है। नाटककारों की रचनाधर्मिता में कबीर के व्यक्तित्व का प्रभाव भी साफ दिखाई देता है।

सहायक ग्रन्थ

भीष्मसाहनी – कबिरा खड़ा बज़ार में

नरेन्द्र मोहन – कहै कबीर सुनो भाई साधो

मणि मधुकर – इकतारे की आंख

राज किशोर – कबीर की खोज

सुमन कुमार – नटरंग सितम्बर २००३

तनाव के कारण एवं कारक

“तनाव” एक ऐसी मनः स्थिति है, जो हर पल मनुष्य को खाए रहती है, लेकिन फिर भी उसका कहीं कोई समाधान नहीं होता, क्योंकि ‘तनाव’ में व्यक्ति अपनी सूझ-बूझ और सोचने-समझने की शक्ति खो देता है, जिसका मस्तिष्क पर सीधा असर पड़ता है, क्योंकि मस्तिष्क में ही भावनाओं, विचारों, उत्तेजना और सपनों का सृजन होता है। भौतिकतावाद, औद्योगिक विकास, संयुक्त परिवार के विध्वंस और केंद्रीय परिवार के गठन, ग्रामीण जनसंख्या का शहरों की ओर पलायन ने जहाँ एक ओर भारतीय मन की असुरक्षा और कमज़ोरी को उजागर किया वहीं उसके विपरीत आध्यात्मिक पक्ष के अभाव ने इस जटिल सामाजिक, आर्थिक एवं आध्यात्मिक पक्ष का असर मानव मन में ‘तनाव’ के रूप में दिखाई दिया।

तनाव के स्वरूप को अधिक अच्छी तरह स्पष्ट करते हुए आचार्य बालकृष्ण जी कहते हैं कि “तनाव का मस्तिष्क पर सीधा असर पड़ता है, क्योंकि मस्तिष्क में ही भावनाओं, विचारों, उत्तेजना और सपनों का सृजन होता है। मस्तिष्क को जब लगातार तथा क्षमता से अधिक कार्य करना पड़ता है तो मानसिक तनाव उत्पन्न होता है।”¹ मानसिक तनाव सौंदर्य का भी शत्रु है। खूबसूरत चेहरे की रंगत उड़ जाती है। सिर के बाल झड़ने लगते हैं। खिंचाव, खीझ और मायूसी भरे चेहरे में कोई आकर्षण नहीं रह जाता। बहुत लोगों के लिए कर्म ही तनाव का मुख्य कारण है। कई लोग १६-१८ घंटे कार्य करते हैं एवं कार्य में ही आनंद की अनुभूति करते हैं। कार्य से उत्पन्न तनाव का मुख्य कारण है - कार्य से असंतुष्टि या असंतोष। भावात्मक सहयोग का अभाव भी तनाव के स्तर को बढ़ाने में अपनी अहम् भूमिका निभाता है। व्यक्ति अपने संबंधियों, पत्नी, बच्चों एवं अच्छे विश्वसनीय मित्रों से भी काफी उत्साह प्राप्त कर सकता है। इसके अभाव में उसे तनाव झेलना पड़ता है। ‘बृहत् हिन्दी कोश’ के अनुसार -

“तनने का भाव या क्रिया, खींचतान, द्वेष या विकर्षण की स्थिति, टेंशन, कहानी या उपन्यास में ग्रहित वह स्थिति जो भिन्न मूल्यों तत्वों या परिप्रक्ष्य आदि की टकराहट में उत्पन्न होती है।”² स्वाधीनतापूर्व ‘तनाव’ की स्थिति को देखा जाए तो स्पष्ट होता है कि तनाव अंग्रेजी सत्ता एवं भारतीय विचारकों की वैचारिक भिन्नता में ही पाया जाता है। स्वाधीनता प्राप्ति के पश्चात यह तनाव ‘स्वान्तः सुखाय’ के लिए होने लगा। समानता का अधिकार, बोलने का अधिकार, स्वतंत्र रूप में विहार करने का अधिकार प्राप्त होते ही ‘तनाव’ ने विचारों से पलटा खाकर मनुष्य के मनों से, शरीर में संचार करना आरंभ कर दिया। फिर क्या था विचार, मन, शरीर, मस्तिष्क, समाज, घर यहाँ तक कि परिवारों में भी ‘तनाव’ ने बदलते युग की आधुनिकता की तरह प्रवेश कर दिया।

तनाव सेरेब्रल कार्टेक्स एवं भावनात्मक कार्टेक्स के मध्य असंतुलन होने के कारण उत्पन्न होता है। तनाव निम्नलिखित कारकों से पनपता है।

१. “बाह्य कारण” : मनुष्य की दिनचर्या, कार्य पद्धति एवं आस-पास का वातावरण तनाव उत्पन्न कर सकता है।
२. आंतरिक कारण : मनुष्य अनुवांशिकीय एवं परिस्थितिजन्य घटकों से मिलकर बना है। अनुवांशिकीय कारणों पर हमारा कोई नियंत्रण नहीं होता है। परंतु यह हमारे मनोवैज्ञानिक स्वास्थ्य हेतु अत्यंत आवश्यक है। अनुवांशिकीय

Dr. Smitha Chacko
Guest Lecturer
Hindi Department
Catholicate College
Pathanamthitta

कारक हमारे विश्वास, आशाओं, व्यवहार, अपेक्षाओं आदि को मूर्तरूप प्रदान करता है।^{१३}

तनाव के बाह्य कारण : बाह्य कारण हमारे कार्य एवं आस-पास के वातावरण पर निर्भर करता है। इनके कुछ मुख्य उदाहरण निम्न लिखित है। -

‘समाज एवं परिवार’ - परिवार के सदस्यों से अपेक्षित व्यवहार न मिलना, संवाद में कमी होना, मूल मान्यताओं में भिन्नता होना आदि के कारण तनाव होता है।

‘कार्य-व्यवसाय’ - जहाँ हम कार्य करते हैं वहाँ तनाव के विभिन्न कारण हो सकते हैं। जैसे स्पष्ट कार्य का निर्धारण न होना, प्रशंसा न मिलना, नियमों से संतुष्ट न होना, अपनी रुचि के अनुसार कार्य न मिलना आदि।

आर्थिक - वित्तीय समस्या एवं आर्थिक परिवर्तन के कारण जैसे धन का अभाव, धन की बचत का सही तरह से न कर पाना तथा सरकार की नीतियाँ, आर्थिक समस्या आदि के कारण भी तनाव होता है।

मान्यताएँ - हम क्या चाहते हैं एवं क्या करना चाहिए यह हमारे जीवन की विभिन्न स्थितियों पर निर्भर करता है। हमारी प्राथमिकताएँ, हमारे विश्वासों एवं मान्यताओं पर भी निर्भर होती है।

संवादशीलता - हम किस प्रकार से अपने विचारों और भावनाओं को प्रकट करते हैं यह हमारे घर तथा कार्य - स्थल के वातावरण पर निर्भर करता है।

आंतरिक कारण - आंतरिक कारण हमारे व्यवहार पक्ष का निर्धारण करते हैं। इनके कुछ प्रमुख उदाहरण निम्नलिखित है -

माता - पिता : माता - पिता का व्यवहार, उनके अनुभव एवं उनके आपसी संबंध, बच्चों पर अमिट छाप छोड़ते हैं जिनका हमारे व्यवहार पक्ष पर बहुत अधिक प्रभाव पड़ता है।

शिक्षण संस्थान - हमारे स्कूल एवं शिक्षकों का हमारे व्यक्तित्व के निर्माण में बहुत महत्वपूर्ण योगदान होता है।

व्यक्तिगत अनुभव : शिक्षा - दीक्षा के समय के आरंभ से ही जब हमारे व्यवहार, हमारी सोच, लाभ, हानि, आशा, निराशा एवं उपलब्धियों आदि के अनुसार हमारी मानसिक संरचना का विकास होता है तब हम भविष्य में इन्हीं अनुभवों के आधार पर अपनी समस्त क्रियाओं - प्रतिक्रियाओं को संपादित करते हैं।

“तनाव” के शिकार ऐसे व्यक्ति होते हैं जो असंतुलित जीवन यापन करते हैं। कुछ लोग तरह - तरह की परिस्थितियों में इतनी प्रतिक्रिया दर्शाते हैं जो उनके लिए तनाव का कारण बन जाता है। यह कुछ चारित्रिक गुणों के कारण होता है, जो व्यक्ति को तनाव का शिकार बनाता है।^{१४} जैसे - अत्यधिक परिश्रमी, आराम से कार्य करना, दूसरों के संदेह पर स्पष्टवादी होना, अपनी कमियों को जानना आदि। यह शरीर कुछ ऐसी क्रियाएँ करता है जो तनाव होने पर होती हैं। तनाव का सीधा असर शरीर पर पड़ता है जिससे कई दुष्परिणाम शरीर पर होते हैं। उपर्युक्त बातों से स्पष्ट है कि ‘तनाव’ वह स्थिति है जिसमें मनुष्य स्वयं को अकेला, किसी की सहायता का मोहताज, निकम्मा, दया का पात्र समझ बैठता है। स्वयं सहनशीलता को रबड़ की तरह तानने का भरसक यत्न जी ज़ोर से करता है और ‘डिप्रेसन’ का शिकार बन जाता है।

संदर्भ सूची

- १ आचार्य बालकृष्ण, विज्ञान की कसौटी पर योग, पृ. १३७
- २ बृहत् हिंदी कोश, ज्ञान मण्डल लिमिटेड, वारणसी
- ३ आचार्य बालकृष्ण, विज्ञान की कसौटी पर योग, पृ. १४२
- ४ डॉ. वीरश्री वशिष्ठजी आर्य, मालती जोशी के कथा-साहित्य में पारिवारिक तनाव, पृ.७०, सं. प्रथम २०१२

उदय प्रकाश की कहानी 'पॉल गोमरा का स्कूटर' में सामाजिक चेतना

'समाज' मानव के सामाजिक संबंधों का गतिशील स्वरूप है। मनुष्य समाज में रहकर ही सामाजिक संबंधों के अस्तित्व को जान सकता है। समाज परिवर्तनशील है। यह परिवर्तन उत्तराधुनिकता के इस दौर में भी जारी रही है।

उत्तराधुनिकता एक निश्चित विचार से अधिक एक प्रवृत्ति का नाम है। व्यक्ति और समाज की स्वतंत्रता के पक्ष में सोच-विचार करती है और साथ ही इस स्वतंत्रता की सीमा भी निर्धारित करती है। उत्तराधुनिकता व्यक्ति को एक अस्मितापूर्ण अस्तित्व प्रदान करती है। इस के केन्द्र में बहुराष्ट्रीय भूमंडलीयता है। भौतिकता की बाढ़ आ गई है। अवमूल्यन ही जीवन समाज का सच हो गया है। भूमंडलीकरण हर क्षेत्र में अपनी चालाकी कई तरह से दिखा रहा है। इस संदर्भ में उदय जी की 'पॉल गोमरा का स्कूटर' कहानी खास महत्व रखती है।

श्री उदय प्रकाश हिन्दी के एक महत्वपूर्ण कवि के साथ-साथ अप्रतिम कथाकार भी है। हिन्दी साहित्य में ऐसे कम रचनाकार हुए हैं, जिन्होंने काव्य और कथा विधा में अविस्मरणीय रचनाएँ दी हैं। उदय प्रकाश जी का समस्त लेखन एक यात्रा है। उनकी सभी कहानियाँ सामाजिक संरचनाओं और प्रक्रियाओं पर केन्द्रित हैं। सामंतवाद, उपनिवेशवाद और भूमंडलीकरण जैसे सभी व्यवस्थाओं की विसंगतियों को लेखक ने अपनी रचनाओं के माध्यम से उभारा है।

उदयप्रकाश जी की एक बहुचर्चित कहानी है 'पॉल गोमरा का स्कूटर'। यह आधुनिक भावबोध से लिखि गयी एक कहानी है। रामगोपाल सकसेना से पॉल गोमरा बने हिन्दी के कवि एक छोटे से दफ्तर में अफसर थे। वह सिद्धांतों और विचारों से क्रांति और परिवर्तन के प्रबल-समर्थक थे। आज हर क्षेत्र में तेजी से परिवर्तन हो रहा है। राजधानी दिल्ली के एक साधारण अखबार में काम करनेवाले हिन्दी कवि रामगोपाल ने अपने नाम का कलात्मक विखंडन कर उसे पॉल गोमरा बना दिया। नित्य ही टी.वी. पर खूबसूरत मॉडलों को देखनेवाले पॉल गोमरा पत्नी सहवास के उदात्त क्षणों में मेहरजेस्सिया मॉडल को भोगते हैं। अपनी कुछ हैसियत को ऊँचा उठाने के लिए अपने नाम को बदलने और स्कूटर को वे कभी नहीं चला पाते। एक नीरस ज़िन्दगी बिताने के लिए विवश पॉल गोमरा को एक अफसर साहित्यकार के सम्मान में इंडिया इटरनेशनल में आयोजित डिनर में शामिल होने का आमंत्रण मिला। अपने दोस्त के रोकने के बाद भी वे वहाँ गये। उन्होंने पीकर अभद्र व्यवहार किया। शिष्ट भद्रजनों के बीच ऐसे व्यवहार करने के कारण लोग उसे धक्के मारकर निकाल जाना उचित माना। मित्र के साथ नशे की हालत में वापस लौटते हुए पॉल गोमरा और मित्र दुर्घटनाग्रस्त हो जाते हैं। पॉल गोमरा विक्षिप्त होकर सड़कों पर भाषण देने लगते हैं और दिल्ली की ओर पत्थर फेंक कर अंग्रेजों के मानस पुत्र भारतीय हुक्मरानों को गालियाँ बकते हुए भारत छोड़ने के लिए कहते हैं।

उत्तर आधुनिक युग में विज्ञापन एक सशक्त माध्यम है। जिसके जरिए गुणविहीन वस्तुओं का वर्चस्व स्थापित होता है। ऐसे विज्ञापन लोगों को भ्रमित करने में सक्षम दिखते हैं। विज्ञापनों में सुन्दर मॉडल्स... के द्वारा लोगों को गुमराह किया जाता है। मल्टीनेशनल कंपनियाँ इस तरह की विज्ञापनों की सहायता से अपनी

Dr. Sobhitha Sebastian

Asst. Professor
Dept. of Hindi
St. Joseph's College
Moolamattom.

प्रोजेक्ट बेचती है। प्रस्तुत कहानी के नायक 'पॉल गोमरा' व्यक्ति पर होनेवाले प्रभाव का सशक्त उदाहरण है। कवि पॉल गोमरा को अपनी पत्नी स्नेहलता सकसेना, मॉडल मेहर जेस्सिया जैसी लगती है। ऐसी तरह की दूसरी एक घटना कहानी में है, आठ महीने पहले किशनगंज के जनता फ्लैट में रहनेवाली हॉस्पिटल के सफाई कर्मचारी राम औतार की सत्रह साल की बेटी सुनीता टी.वी. की विज्ञापन में न्यूड सीन देखकर रातोंरात मालमाल हो गई।

उपभोक्तावाद के इस युग में बाज़ार का जादू सब पर पूरी तरह छाया हुआ है। आज औरत बिकाउ और मर्द कमाउ बन गया है। मीडिया और बाज़ार की ताकत से रचे जाते इस यथार्थ में लिप्सा और आक्रामकता के नये समीकरण बन रहे हैं। 'पॉल गोमरा का स्कूटर' कहानी में उदय प्रकाश जी ने फैंटेसी के माध्यम से उस विसंगत यथार्थ को उभारने की कोशिश की है। बड़े-बड़े कविगण मुक्त बाज़ार और व्यावसायिक प्रतिस्पर्धा के विरुद्ध जान कर रहे हैं। अपने आस-पास फैली लालच, भ्रम, अपराध और पूँजी नाम से भरी दुनिया में भी यह कवि होने के सपने पालता है। लेकिन तेजी से माल गोदाम बनते इस समाज में उसका कोई मूल्य नहीं है। गोमरा पावरफूल मनीड पीपल से अपनी लड़ाई में पुअर सिंपल वीक हिन्दी पोएट लडते विक्षिप्त हो जाता है।

शताब्दी के अंतिम पड़ाव में हुआ निजीकरण, भूमंडलीकरण, विकसित हो रही बाजारी संस्कृति का चित्रण इस कहानी में देखने को मिलता है। इस कहानी की अंतिम पंक्तियाँ हैं - "जो प्रजातियाँ लुप्त हो रही हैं, यथार्थ मिटा रहा है जिनका अस्तित्व। हो सके तो हम उनकी हत्या में न हो शामिल और संभव हो तो सँभालकर रख लें उनके चित्र...। ये चित्र अतीत के स्मृति चिन्ह हैं...।"⁹ ये पंक्तियाँ कवि पॉल गोमरा की हैं।

इस कहानी की सामाजिक चेतना पर विचार करने पर यह स्पष्ट होता है कि नारी जीवन की विडंबनावों का सच्चा चित्रण इसमें है। स्त्री केवल शरीर के रूप में देखी जाती है। बाजारी संस्कृति में नारी शरीर दिखाऊ चीज़ बन गयी है। इस के विरुद्ध आवाज़ उठाना भी कहानीकार का लक्ष्य है। उत्तराधुनिक जीवन में व्याप्त दिखावा और घोघलापन भी इस कहानी में दृष्टव्य है। संक्षेप में कहा जा सकता है कि उदय प्रकाश जी की कहानी 'पॉल गोमरा का स्कूटर' उत्तराधुनिकता की विसंगतियों का खुला दस्तावेज़ है।

संदर्भ सूचि

1. अपनी उनकी बात, उदय प्रकाश, पॉल गोमरा का स्कूटर, पृ. ७६

A Comparative Study on College Level Athletes and Non Athletes among Self Esteem

Abstract

The purpose of the study was to compare the level of self esteem on athletes and non athletes in college level students. Nowadays the level of competition has to be increased dramatically in our society for gaining some jobs and positions. There for our students needs high level of self esteem and confidence to achieve something special. Self-esteem is attractive as a social psychological construct because researchers have conceptualized it as an influential predictor of certain outcomes, such as academic achievement, happiness, satisfaction in marriage and relationships, and criminal behavior. The subjects were selected from St. Thomas College Palai, CMS College Kottayam, KE College Mannanam and Dhevamatha College Kuravilangadu . A total of hundred (N= 100) male subjects were selected, equally divided and assigned to two group's (n = 50) namely athletes group and non athletes group. The age range of the subjects was in between the 20-25. Investigator was directly visited these institutions and collected the scores by personally. Rosenberg self esteem scale was utilized to measure the subjects self esteem. The investigator had made a brief introduction about the questionnaire and about the answering at the beginning of the testing. Sufficient time was given for the subjects to fill the questionnaire. After taking the raw scores of the subjects, the difference between the groups was found out by using Independent 't' ratio. The result of the study has shown that the each athlete's group and non athletes group have shown above average score. The athletes group has shown highest score than the non-athlete group. From this result we can understand that the physical activities have the ability to make the students as more confident and esteemed. There for it is clear that physical activity is an essential thing to develop humans in both physically and mentally.

Introduction

In sociology and psychology, self-esteem reflects a person's overall subjective emotional evaluation of his or her own worth. It is a judgment of oneself as well as an attitude toward the self. Self-esteem is attractive as a social psychological construct because researchers have conceptualized it as an influential predictor of certain outcomes, such as academic achievement, happiness, satisfaction in marriage and relationships, and criminal behavior. Self-esteem can apply specifically to a particular dimension (for example, "I believe I am a good

Bintu T Kalyan

Assistant Professor
Dept. of Physical Education
St. Thomas College Pala
Kottayam Dist. Kerala

writer and feel happy about that”) or a global extent (for example, “I believe I am a bad person, and feel bad about myself in general”). Psychologists usually regard self-esteem as an enduring personality characteristic (“trait” self-esteem), though normal, short-term variations (“state” self-esteem) also exist. Synonyms or near-synonyms of self-esteem include: self-worth, self-regard, self-respect, and self-integrity.

Self esteem is the quality, which is essential for a student for his or her better future. Through this study the investigator trying to know that what the state of our students self esteem level is. Studies have proven that, the physical activities can improve one’s self esteem for some extent. There for the researcher has made a study in between college level men students.

The following are guidelines to follow for fostering self esteem:

- Look at each child as a unique person
- Keep expectations realistic
- Give the freedom to make mistakes
- Build in success
- Give encouragement
- Accept children’s unpleasant feelings and teach them how to deal with them
- Give choices
- Give responsibility and expect cooperation
- Keep your sense of humor each child is truly unique.

Aim and Objectives of the Study

- To find out the students’ self-esteem level
- Role of sports in student’s life
- To find out the effect of physical activity in humans life
- Educate the students about the benefits of physical activity

Methodology

The subjects were selected from St. Thomas College Palai, CMS College Kottayam, KE College Mannanam and Dhevamatha College Kuravilangadu . A total of hundred (N= 100) male subjects were selected, equally divided and assigned to two group’s (n = 50) namely athletes group and non athletes group. The age range of the subjects was in between the 20-25. Investigator was directly visited these institutions and collected the scores by personally. Rosenberg self esteem scale was utilized to measure the subjects self esteem. The investigator had made a brief introduction about the questionnaire and about the answering at the beginning of the testing. Sufficient time was given for the subjects to fill the questioner.

Selection of Questionnaire

Rosenberg self esteem scale – having ten questions with four optional answers

Statistical Technique

Descriptive statistics and Independent ‘t’ tests were utilized for comparing the mean difference between the groups.

Result And Discussions

The questionnaire were collected back and checked it carefully for calculating scores, the investigator got the data regarding the each group is shown below.

Table no. 1 Descriptive Statistics on Self-Esteem Score of the Athletes Group and Non Athletes Group

	Athletes	Non athletes
Mean	34.5	30.3
Mode	32	29
Minimum score	20	18
Maximum score	36	33
Standard deviation	2.89	2.40

Table no.2 The Independent 'T' Score among the Obtained Score (Self Esteem)

Group	N	Mean	Std. Deviation	T	Required T
Athletes	50	34.5	2.89	8.33	2.015
Non athletes	50	30.3	2.40		

Table no. 2 has shown that the both groups have above average self-confidence level. Moreover the athletic group secured more score than the nonathletic group. There for the athletic group having more self-esteem than the non-athlete group.

Findings

From the table no. 2 we can find that the athletes group has shown more self esteem than the non-athlete group, but both groups having above average self esteem level. Self esteem is an essential quality that is required to a student for building a bright future. From this study we found that the involvement of physical activities is help the student to increase their self esteem level. Humans needs to stay physically and mentally healthy

References

1. Dosil, J. The sport psychologist's handbook: A guide for sport-specific performance enhancement. West Sussex, England: John Wiley & Sons, Ltd (2006).
2. Maher, C. A. The role of schools in preventing childhood obesity. In D.Young, R. Pangrazi, and B.Ainsworth (Eds.), President's Council on Physical Fitness and Sports Research Digest, (2005).
3. Seligman, M. E. P., and Csikszentmihalyi, M, School sport psychology: Perspectives, programs, and procedures. New York: The Haworth Press (2000).
4. Kamalesh, M.L., "Methodology of Research in Physical Education and sports", New Delhi, Metropolitan, 1986.
5. Bucher, C.A., "Foundation of physical Education and Sports", 10th ed. St. Louis: Times Mirror, 1987.

Impact of AI on Solar Applications

Abstract

The aim of this paper is to introduce briefly the various AI techniques and to present various applications in solar energy applications. Solar energy applications include the estimation of solar radiation, solar heating, photovoltaic (PV) systems, sun tracking systems, solar air-conditioning systems and many others. AI consists of several branches such as artificial neural network (ANN), fuzzy logic (FL), Adaptive Network based Fuzzy Inference System (ANFIS) and Data Mining (DM). ANN being used in weather and market trends forecasting, in the prediction of mineral exploration sites, in electrical and thermal load prediction, and in adaptive and robotic control. Neural networks are used for process control because they can build predictive models of the process from multidimensional data routinely collected from sensors. Effectively highlighting ANN techniques on solar applications.

Key words: AI Techniques, Artificial Neural Networks, Fuzzy Logic, ANFIS, Genetic Algorithm, Data Mining.

Introduction

Many human mental activities such as writing computer programs, doing mathematics, engaging in commonsense reasoning, understanding language, and even driving an automobile are said to demand “intelligence”. Over the past few decades, several computer systems have been built that can perform tasks such as these. Specifically, there are computer systems that can diagnose diseases, plan the synthesis of complex organic chemical compounds, solve differential equations in symbolic form, analyze electronic circuits, understand limited amounts of human speech and natural language text, or write small computer programs to meet formal specifications. We might say that such systems possess some degree of artificial intelligence. Most of the work on building these kinds of systems has taken place in the field called Artificial Intelligence (AI) (Nilsson, 1980). Most AI programs are quite complex objects and mastering their complexity is a major research goal. A comprehensive study of the problems that exist in AI programs requires a precise formalization so that detailed analyses can be carried out so as satisfactory solutions can be obtained (Bourbakis, 1992).

M.V. Jisha

Guest Lecturer

Department of Computer Science

N.S.S College, Ottapalam

Palakkad, Kerala

The main objectives of AI research are (Akerkar, 2005)

- Understand human cognition
- Cost-effective automation replaces humans in intelligent tasks.
- Cost-effective intelligent amplification builds systems to help humans think better, and faster.
- Superhuman intelligence builds programs to exceed human intelligence.
- General problem-solving solves a broad range of problems.
- Coherent discourse communicates with people using natural language.
- Autonomy has intelligent systems acting

The aim of this paper is to introduce briefly the various AI techniques and to present various applications in solar energy applications. Solar energy applications include the estimation of solar radiation, solar heating, photovoltaic (PV) systems, sun tracking systems, solar air-conditioning systems and many others. Therefore, the possibilities of applying AI in solar energy applications will be shown.

AI Techniques

AI techniques have the potential for making better, quicker and more practical predictions than any of the traditional methods. AI consists of several branches such as artificial neural network (ANN), fuzzy logic (FL), Adaptive Network based Fuzzy Inference System (ANFIS) and Data Mining (DM).

Artificial Neural Networks (ANN)

Neural networks are composed of simple elements operating in parallel. These elements are inspired by biological nervous systems. As in nature, the network function is determined largely by the connections between elements. A neural network can be trained to perform a particular function by adjusting the values of the connections (weights) between the elements. Commonly neural networks are adjusted, or trained, so that a particular input leads to a specific target output. Such a situation is shown in Fig 1. Here, the network is adjusted, based on the comparison between the output and the target, until the network output matches the target. Typically many such input/target output pairs are needed on own initiative.

- Training of the system should be able to gather own data.
- Store information and know how to retrieve it.

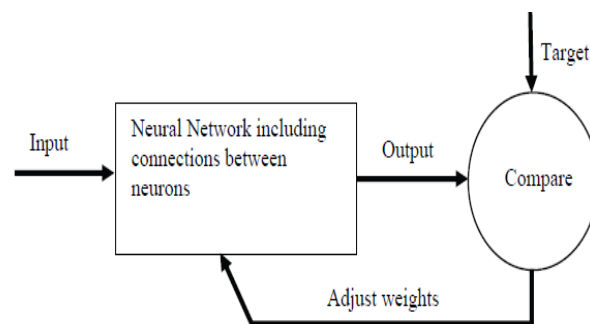

Fig . 1 . Basic Principles of Artificial Neural Networks

ANNs have been applied successfully in a number of application areas. Some of the most important ones are (Kalogirou , 2000; 2001):

1. **Function approximation.** Mapping of a multiple input to a single output is established. Unlike most statistical techniques, this can be done with adaptive model-free estimation of parameters.

2. **Pattern association and pattern recognition.** This is a problem of pattern classification. ANNs can be effectively used to solve difficult problems in this field, for instance in sound, image, or video recognition. This task can even be made without an *a priori* definition of the pattern. In such cases the network learns to identify totally new patterns.

3. **Associative memories.** This is the problem of recalling a pattern when given only a subset clue. In such applications the network structures used are usually complicated, composed of many interacting dynamical neurons.

4. **Generation of new meaningful patterns.** This general field of application is relatively new. Some claims are made that suitable neuronal structures can exhibit rudimentary elements of creativity.

ANNs have been applied successfully in various fields of mathematics, engineering, medicine, economics, meteorology, They have also being used in weather and market trends forecasting, in the prediction of mineral exploration sites, in electrical and thermal load prediction, and in adaptive and robotic control. Neural networks are used for process control because they can build predictive models of the process from multidimensional data routinely collected from sensors psychology, neurology, and many others. Some of the most important ones are in pattern, sound and speech recognition, in the analysis of electromyographs and other medical signatures, in the identification of military targets and in the identification of explosives in passenger suitcases. (Kalogirou, 2000; 2001).

The network usually consists of an input layer, some hidden layers and an output layer. In its simple form, each single neuron is connected to other neurons of a previous layer through adaptable synaptic weights. Knowledge is usually stored as a set of connection weights (presumably corresponding to synapse efficacy in biological neural systems). Training is the process of modifying the connection weights in some orderly fashion using a suitable learning method. The network uses a learning mode, in which an input is presented to the network along with the desired output and the weights are adjusted so that the network attempts to produce the desired output. The weights after training contain meaningful information whereas before training they are random and have no meaning (Kalogirou, 2000; 2001). Fig 2 illustrates how information is processed through a single node. The node receives weighted activation from other nodes through its incoming connections. First, these are added up (summation). The result is then passed through an activation function; the outcome is the activation of the node. For each of the outgoing connections, this activation value is multiplied by the specific weight and transferred to the next node.

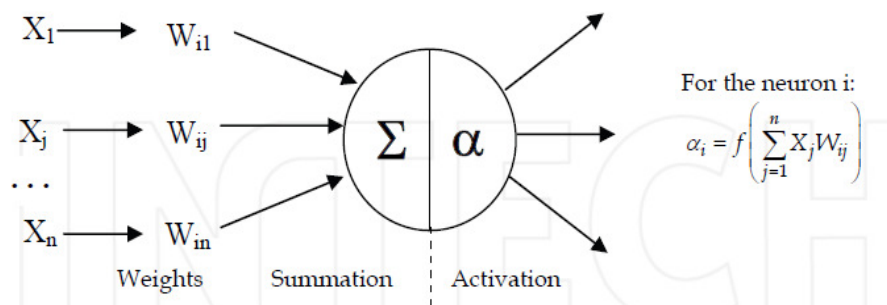

Fig. 2. Information processing in a neural network unit

B. Fuzzy Logic (FL)

Fuzzy logic has two different meanings. In a narrow sense, fuzzy logic is a logical system, which is an extension of multi-valued logic. However in a wider sense, fuzzy logic (FL) is almost

synonymous with the theory of fuzzy sets, a theory which relates to classes of objects with un-sharp boundaries in which membership is a matter of degree. In this perspective, fuzzy logic in its narrow sense is a branch of fuzzy theory. Even in its more narrow definition, fuzzy logic differs both in concept and substance from traditional multi-valued logical systems (MATLAB Fuzzy logic toolbox user's guide).

The following is a list of general observations about fuzzy logic:

- **Fuzzy logic is conceptually easy to understand.** The mathematical concepts behind fuzzy reasoning are very simple. Fuzzy logic is a more intuitive approach without the far reaching complexity.
- **Fuzzy logic is flexible.** With any given system, it is easy to add on more functionality without starting again from scratch.
- **Fuzzy logic is tolerant of imprecise data.** Everything is imprecise if you look closely enough, but more than that, most things are imprecise even on careful inspection. Fuzzy reasoning builds this understanding into the process rather than tacking it on to the end.
- **Fuzzy logic can model nonlinear functions of arbitrary complexity.** You can create a fuzzy system to match any set of input-output data. This process is made particularly easy by adaptive techniques like Adaptive Neuro-Fuzzy Inference Systems (ANFIS), which are available in Fuzzy Logic Toolbox software.
- **Fuzzy logic can be built on top of the experience of experts.** In direct contrast to neural networks, which use training data and generate opaque, impenetrable models, fuzzy logic lets you rely on the experience of people who already understand the system.
- **Fuzzy logic can be blended with conventional control techniques.** Fuzzy systems don't necessarily replace conventional control methods. In many cases fuzzy systems augment them and simplify their implementation.
- **Fuzzy logic is based on natural language.** The basis of fuzzy logic is human communication. This observation underpins many of the other statements about fuzzy logic. Because fuzzy logic is built on the structures of qualitative description used in everyday language, fuzzy logic is easy to use (MATLAB Fuzzy logic toolbox user's guide).

Generally, a fuzzy logic model is a functional relation between two multidimensional spaces. The relation between the input and output fuzzy spaces is known as fuzzy associative memories (FAM). Inside FAM, the linguistic variables and the attributes are specified and the associative rules between different fuzzy sets are elaborated in order to set up the following construction:

IF (premises) THEN (conclusions)

Every premise or conclusion consists of expressions as (variable) IS (attribute) connected through the fuzzy operator AND.

To implement a fuzzy system the following steps needs to be followed:

- **Fuzzification** is a coding process in which each numerical input of a linguistic variable is transformed in the membership function values of attributes.
- **Inference** is a process which is done in two steps: (i) The computation of a rule by intersecting individual premises, applying the fuzzy operator AND, (ii) Often, more rules drive to a same conclusion. To obtain the confidence level of this conclusion (i.e.the membership function value of a certain attribute of output linguistic variable) the individual confidence levels are joined by applying the fuzzy operator OR.
- **Defuzzification** is a decoding operation of the information contained in the output fuzzy sets resulted from the inference process, in order to provide the most suitable output crisp value. There are a

number of methods which can be used for defuzzification presented by Paulescu et al. (2008).

C. Adaptive Network based Fuzzy Inference System (ANFIS)

The ANFIS model is a hybrid framework that is obtained by combining the concepts of fuzzy logic and neural networking into a unified platform. The model has a fuzzy inference system in the form of an adaptive network for system identification and a predictive tool that maps a given input space to its corresponding output space based on a representative training data set. The ANFIS inference system relies on both fuzzified human knowledge (modelled in the form of fuzzy “if-then” rules) and a set of input–output data pairs (patterns) to accomplish the process of input–output mapping. The ANFIS modelling strategy is widely used in applications or systems that involve uncertainty or imprecision in the definitions of the variables constituting the system’s behavior . In other words, it has the ability to qualitatively model and represent human knowledge without the need for precise or quantitative definitions. Moreover, it is capable of modeling and identifying nonlinear systems as well as predicting chaotic time-dependant behavior (Soyguder and Alli, 2009). There are mainly two approaches for fuzzy inference systems namely Mamdani and Sugeno. The difference is originated from the consequent part where fuzzy membership functions are used in Mamdani and linear or constant functions are used in Sugeno. One must have data at hand in order to apply Sugeno approach, whereas there is no such requirement for Mamdani approach (Ozger and Yýldýrym, 2009). The architecture of ANFIS is shown in Fig. 3.

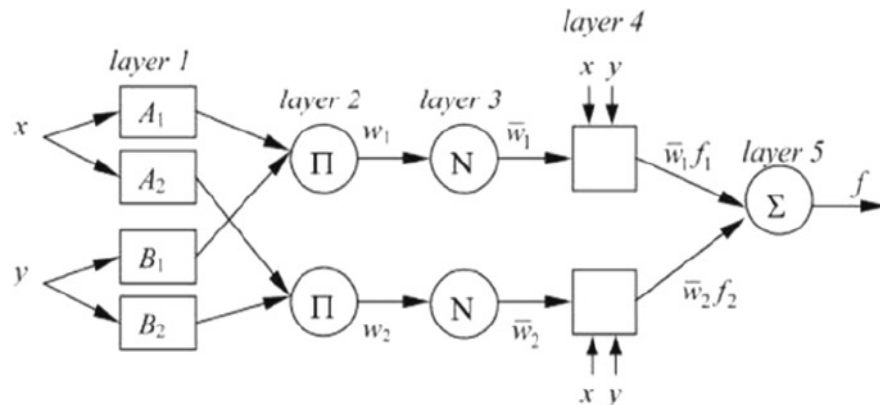

Fig 3. ANFIS Architecture

The functionality of nodes in ANFIS can be summarized as follows (Efendigil et al., 2009):

- *Layer 1*: Nodes are adaptive; membership functions (MFs) of input variables are used as node functions, and parameters in this layer are referred to as antecedent or premise parameters.
- *Layer 2*: Nodes are fixed with outputs representing the firing strengths of the rules.
- *Layer 3*: Nodes are fixed with outputs representing normalized firing strengths.
- *Layer 4*: Nodes are adaptive with node function given by Layer 1 for a first-order model, and with parameters referred to as defuzzifier of consequent parameters.
- *Layer 5*: The single node is fixed with output equal to the sum of all the rules’ outputs.

D. Genetic Algorithms (GA)

Genetic algorithms are inspired by the way living organisms adapt to the harsh realities of life in a hostile world, i.e., by evolution and inheritance. The algorithm imitates the process of evolution of populations by selecting only fit individuals for reproduction. Therefore, a genetic algorithm is an optimum search-technique based on the concepts of natural selection and survival of the fittest. It

works with a fixed-size population of possible solutions of a problem, called individuals, which are evolving in time. A genetic algorithm utilizes three principal genetic operators: selection, crossover and mutation (Kalogirou, 2004). During each step (called a generation) in the reproduction process, the individuals in current generation are evaluated by a fitness-function, which is a measure of how well the individual solves the problem. Then each individual is reproduced in proportion to its fitness: the higher the fitness, the higher its chance to participate in mating (crossover) and to produce an offspring. A small number of newborn offspring undergo the action of the mutation operator. After many generations, only those individuals who have the best genetics (from the point of view of the fitness function) survive. The individuals that emerge from this “survival of the fittest” process are the ones that represent the optimal solution to the problem specified by the fitness function and the constraints (Kalogirou, 2004).

Genetic algorithms (GA) are suitable for finding the optimum solution in problems where a fitness function is present. Genetic algorithms use a “fitness” measure to determine which of the individuals in the population survive and reproduce. Thus, survival of the fittest causes good solutions to progress. A GA works by selective breeding of a population of “individuals”, each of which could be a potential solution to the problem. The structure of the standard genetic algorithm is shown in Fig. 4.

Genetic Algorithm

```

Begin (1)
  t = 0 [start with an initial time]
  Initialize Population P(t) [initialize a usually random population of individuals]
  Evaluate fitness of Population P(t) [evaluate fitness of all individuals in population]
  While (Generations < Total Number) do begin (2)
    t = t + 1 [increase the time counter]
    Select Population P(t) out of Population P(t-1) [select sub-population for
                                                    offspring production]

    Apply Crossover on Population P(t)
    Apply Mutation on Population P(t)
    Evaluate fitness of Population P(t) [evaluate new fitness of population]
  end (2)
end (1)

```

Fig.4. The structure of a standard genetic algorithm

With reference to Fig. 4, in each generation, individuals are selected for reproduction according to their performance with respect to the fitness function. Actually, selection gives a higher chance of survival to better individuals. Subsequently, genetic operations are applied in order to form new and possibly better offspring. The algorithm is terminated either after a certain number of generations or when the optimal solution has been found (Kalogirou, 2004).

E. Data Mining (DM)

Data mining is a powerful technique for extracting predictive information from large databases. The automated analysis offered by data mining goes beyond the retrospective analysis of data. Data mining tools can answer questions that are too time-consuming to resolve with methods based on first principles. In data mining, databases are searched for hidden patterns to reveal predictive information in patterns that are too complicated for human experts to identify (Hoffmann & Apostolakis, 2003). Data mining is applied in a wide variety of fields for prediction, e.g. stock-prices, customer behaviour, and production control. In addition, data mining has also been applied to other types of scientific data such as astronomical and medical data (Li & hue, 2004). Data understanding starts with an initial data collection and proceeds with activities to get familiar with the .data, to identify data quality problems,

and to discover first insights into the data. Data preparation covers all activities that construct the final data set to be modelled from the initial raw data. The tasks of this phase may include data cleaning for removing noise and inconsistent data, and data transformation for extracting the embedded features (Li & Shue, 2004). Successful mining of data relies on refining tools and techniques capable of rendering large quantities of data understandable and meaningful (Mattison, 1996). The modeling phase applies various techniques, determines the optimal values of parameters in models, and finds the one most suitable to meet the objectives. The evaluation phase evaluates the model found in the last stage to confirm its validity to fit the problem requirements. No matter which areas data mining is applied to, most of the efforts are directed toward the data preparation phase (Li & Shue, 2004). The process of knowledge discovery in databases can be seen in Fig. 5.

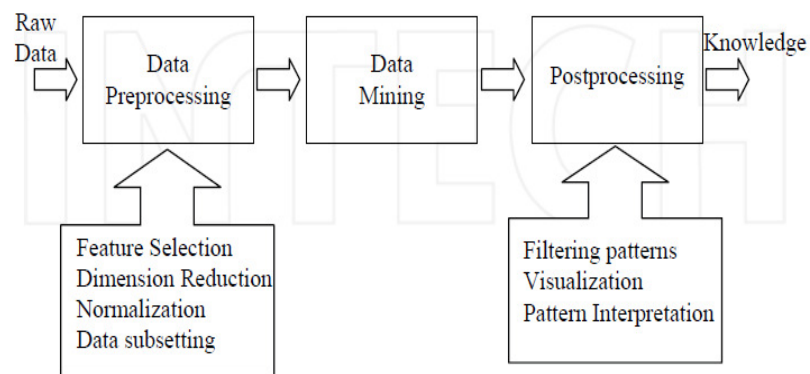

Fig.5. The process of knowledge discovery in databases

III. Applications of Artificial Intelligence (AI) techniques in the solar energy application.

Artificial intelligence techniques have been used by various researchers in solar energy applications. This section deals with an overview of these applications. Some examples on the use of AI techniques in the solar energy applications are summarized in Table 1.

A. Applications of Artificial Neural Networks

Mellit and Pavan (2010) developed a Multi-Layer Perceptron (MLP) network for forecasting 24 h ahead solar irradiance. The mean daily irradiance and the mean daily air temperature are used as input parameters in the proposed model. The output was represented by the 24h ahead values of solar irradiance. A comparison between the power produced by a 20 kWp Grid Connected Photovoltaic Plant and the one forecasted using the developed MLP predictor shows a good prediction performance for 4 sunny days (96 h). As indicated by the authors, this approach has many advantages with respect to other existing methods and it can easily be adopted for forecasting solar irradiance values of (24-h ahead) by adding more input parameters such as cloud cover, pressure, wind speed, sunshine duration and geographical coordinates.

Benghanem et al. (2009) have developed artificial neural network (ANN) models for estimating and modelling daily global solar radiation. They have developed six ANN models by using different combination as inputs: the air temperature, relative humidity, sunshine duration and day of year. For each model, the output is the daily global solar radiation. For each of the developed ANN-models the correlation coefficient is greater than 97%. The results obtained render the ANN methodology as a promising alternative to the traditional approach for estimating global solar radiation.

Rehman and Mohandes (2008) used the air temperature, day of the year and relative humidity

Table 1. Summary of numbers of applications in solar energy applications

AI technique	Area	Number of applications
Artificial neural networks	Prediction of solar radiation	11
	Modelling of solar steam-generator	1
	Prediction of the energy consumption of a passive solar building	1
	Characterization of Si-crystalline PV modules	1
	Efficiency of flat-plate solar collectors	1
	Heating controller for solar buildings	1
	Modelling of a solar air heater	1
Fuzzy logic	Photovoltaic solar energy systems	2
	Sun tracking system	1
	Prediction of solar radiation	5
	Control of solar buildings	1
	Controller of solar air-conditioning system	2
Adaptive Network based Fuzzy Inference System	Prediction of solar radiation and temperature	3
Genetic algorithms	Photovoltaic solar energy systems	2
	Determination of Angström equation coefficients	1
	Solar water heating systems	2
	Hybrid solar-wind system	2
	PV-diesel hybrid system	2
	Solar cell	1
	Flat plate solar air heater	1
Data Mining	Solar cell	1

Table 2. Summary of solar energy applications of Artificial Neural Network

Authors	Year	Subject	
Mellit and Pavan	2010	Prediction of solar radiation	
Benghanem et al.	2009		
Rehman and Mohandes	2008		
Tymvios et al.	2005		
Mubiru and Banda	2008		
Sozen et al.	2004		
Soares et al.	2004		
Zervas et al.	2008		
Elminir et al.	2007		
Senkal and Kuleli	2009		
Moustris, K.	2008		
Kalogirou et al.	1998		Modelling of solar steam-generator
Kalogirou and Bojic	2000		Prediction of the energy consumption of a passive solar building
Almonacid et al.	2009	Characterization of Si-crystalline PV modules	
Sözen et al.	2008	Efficiency of flat-plate solar collectors	
Argiriou et al.	2000	Heating controller for solar buildings	
Esen et al.	2009	Modelling of a solar air heater	

values as input in a neural network for the prediction of global solar radiation (GSR) on horizontal surfaces. For one case, only the day of the year and daily maximum temperature were used as inputs and GSR as output. In a second case, the day of the year and daily mean temperature were used as inputs and GSR as output. In the last case, the day of the year, and daily average values of temperature and relative humidity were used to predict the GSR. Results show that using the relative humidity along with daily mean temperature outperforms the other cases with absolute mean percentage error of 4.49%. The absolute mean percentage error for the case when only day of the year and mean

temperature were used as inputs was 11.8% while when maximum temperature is used instead of mean temperature is 10.3%.

Tymvios et al. (2005) used artificial neural networks for the estimation of solar radiation on a horizontal surface. In addition, they used the traditional and long-utilized Angström's linear approach which is based on measurements of sunshine duration. The comparison of the performance of both models has revealed the accuracy of the ANN.

Mubiru and Banda (2008) used an ANN to estimate the monthly average daily global solar irradiation on a horizontal surface. The comparison between the ANN and empirical method has been given. The proposed ANN model proved to be superior over the empirical model because it is capable of reliably capturing the non-linearity nature of solar radiation. The empirical method is based on the principle of linearity.

Sozen et al. (2004) estimated the solar potential of Turkey by artificial neural networks using meteorological and geographical data (latitude, longitude, altitude, month, mean sunshine duration and mean temperature). The maximum mean absolute percentage error was found to be less than 6.74% and R² values were found to be about 99.89% for the testing stations. For the training stations these values were found to be 4.4% and 99.97% respectively. The trained and tested ANN models show greater accuracy for evaluating the solar resource possibilities in regions where a network of monitoring stations have not been established in Turkey. The predicted solar potential values from the ANN are given in the form of monthly maps.

Soares et al. (2004) used artificial neural networks to estimate hourly values of diffuse solar radiation at a surface in Sao-Paulo City, Brazil, using as input the global solar radiation and other meteorological parameters. It was found that the inclusion of the atmospheric longwave radiation as input improves the neural-network performance. On the other hand traditional meteorological parameters, like air temperature and atmospheric pressure, are not as important as long-wave radiation which acts as a surrogate for cloud-cover information on the regional scale. An objective evaluation has shown that the diffuse solar radiation is better reproduced by neural network synthetic series than by a correlation model.

Zervas et al. (2008) used artificial neural networks to predict the daily global solar irradiance distribution as a function of weather conditions and each calendar day. The model was tuned using the meteorological data recorded by the "ITIA" Meteorological station of National Technical University of Athens, Zografou Campus, Greece. The model performed successfully on a number of validation tests. The future challenge is to extend the model, so that it can predict the output power of 50kWp PV arrays. This model will allow to take optimal decisions regarding the operation and maintenance of the PV panels. This work may prove useful for engineers who are interested in solar energy systems applications from both a general and a more detailed point of view.

Elminir et al. (2007) used an artificial neural network model to predict the diffuse fraction on an hourly and daily scale using as input the global solar radiation and other meteorological parameters, like long-wave atmospheric emission, air temperature, relative humidity and atmospheric pressure. A comparison between the performances of the ANN model with that of linear regression models has been given. The neural network is more suitable to predict diffuse fraction than the proposed regression models at least for the Egyptian sites examined.

Senkal and Kuleli (2009) also used artificial neural networks for the estimation of solar radiation in Turkey. Meteorological and geographical data (latitude, longitude, altitude, month, mean diffuse radiation and mean beam radiation) are used in the input layer of the network. Solar radiation is the output. The selected ANN structure is shown in Fig. 6. By using the ANN and a physical method, solar radiation was predicted for 12 cities in Turkey. The monthly mean daily total values were found to be 54 W/m²